

9308

Heavy-Duty Lock-in/Lock-out Slide

- Up to 300-lb. [136 kg] load rating
- Full extension
- Locks in open and closed position
- Front lever release

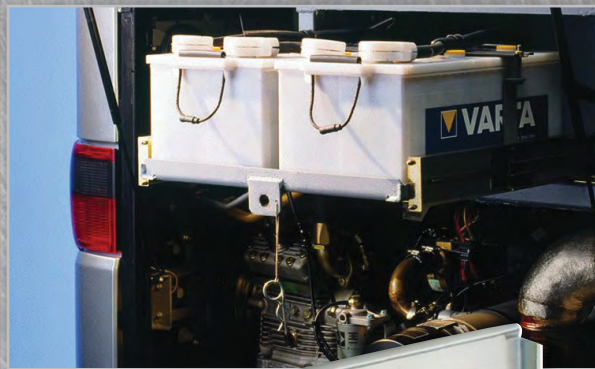

Accuride®



Equipment platforms or pull-outs



Storage trays or equipment drawers

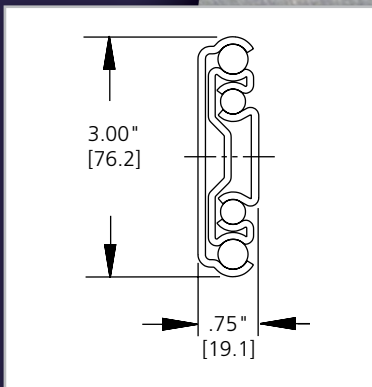

9308

Heavy-Duty Lock-in/Lock-out Slide

Lock-in and lock-out functionality operates with an intuitive front latch mechanism

Model 9308 is designed for a wide range of applications in utility or emergency vehicles such as equipment drawers or platforms, storage trays, tool boards, battery tray pull-outs, and other heavy-duty storage. The lock-out function keeps drawers safely open during access, while the lock-in feature keeps drawers securely closed for transit.

Features & Benefits

- Up to 300-lb. [136 kg] load rating; heavy-duty for mobile applications.*
- Lock-out ensures drawers remain stable while accessing contents.
- Lock-in keeps compartments secure during transit, preventing drawer roll out under harsh conditions such as vibration or impact.
- Front latch release is easy to access, controlling both lock-in and lock-out functions.
- No disconnect method to prevent the accidental removal of drawers, shelves, or trays.

Availability/Packaging

- Clear zinc finish
- Even lengths 12"–36", plus 40", 42", 48", and 60" [305–914, 1016, 1066, 1219, 1524 mm]
- Optional bracket kit provides six additional platform-mounting configurations.**
- Model 9308 may be combined with Model 9301 (non-locking). Available as part number 9308-5, this special packaging includes one standard 9301 and one right-handed 9308. Lengths offered include 14"–36", 40", 42", 48", and 60"

* See product technical sheet for additional load rating information.

** See the 9301 Accessory Platform Bracket technical sheet for further information.

Accuride

12311 Shoemaker Avenue
 Santa Fe Springs, CA 90670
 (562) 903-0200
 (562) 903-0208 Fax
 www.accuride.com

Authorized Distributor

