



MODEL 3832HDSC

Heavy-Duty Self-Closing
Holds drawers in a closed position
Vertical Cam Adjustment
Optional Face Frame Bracket Kit



APPLICATIONS: Use when a stronger self-closing/stay closed action is required such as in mobile storage carts, vehicular applications, or other portable storage units. Not intended for lateral file* drawer applications. **This product is covered by U.S. (6,145,945) and various foreign patents issued and/or pending.**

3832HDSC QUICK REFERENCE

Side space: 1/2" + 1/32" x 2
Length: 12"–28"
Overall slide dimensions: 1.80" x 1/2"
Load Rating: 100 lbs.*

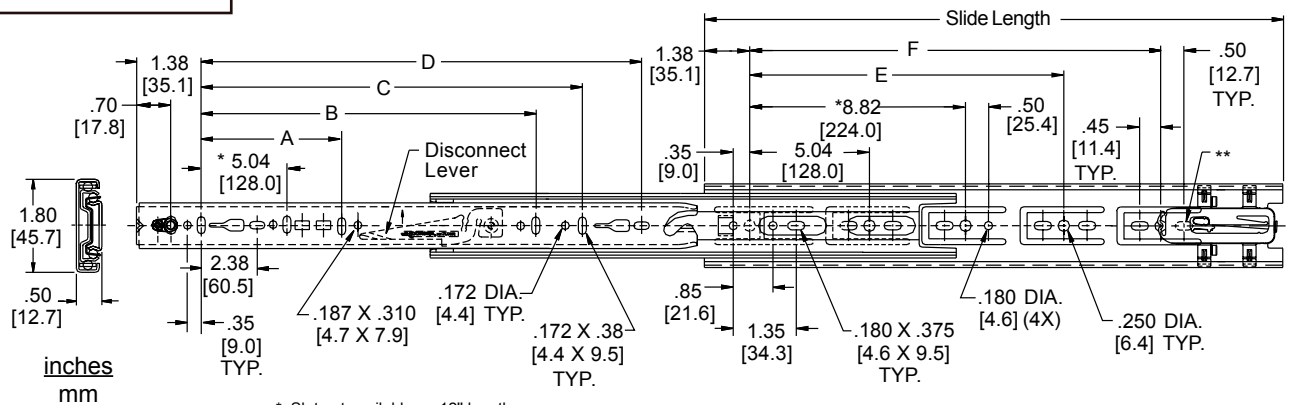
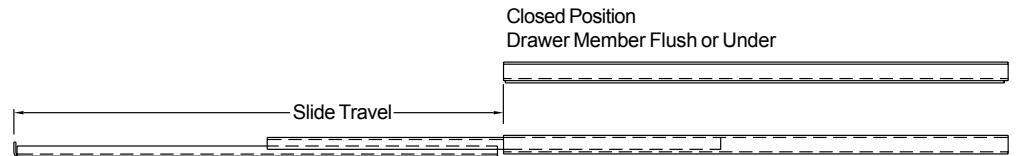
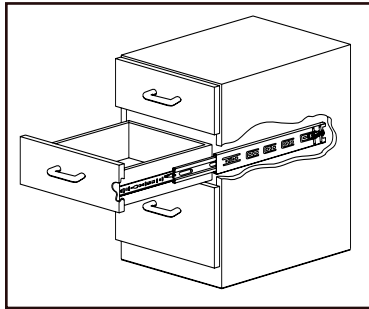

* Slot not available on 12" lengths.
** Slot not accessible on 16" and 20" lengths.

- Finish** Clear zinc (C), black electroplate (CB), or white electrocoat (EW)
- Length** 12"–28" [300 mm–700 mm]
- Load Rating** 100 lbs. [45.5 kg.] per pair *
- Detent Force** 6–9 lbs. [2.7–4.1 kg] per slide
- Travel** Full extension (see chart)
- Disconnect** Handed lever disconnect.
- Height** 1.80" [45.7 mm]
- Side Space** .50" +0.031 / -0.0 [12.7mm +0.8 / -0.0]
- Mounting** Side; optional brackets for face frame mounting.
- Features** Drawer member vertical cam adjustment; Silenced open and closed. Self-close and stay close action eliminates bounce back and drawer creep.

Part Number	Slide Length	Slide Travel	A	B	C	D	E	F	G
3832-C12HDSC	11.81 [300]	11.25 [286]					9.09 [231]		
3832-C14HDSC	13.78 [350]	14.00 [356]					11.06 [281]		
3832-C16HDSC	15.75 [400]	16.00 [406]					13.03 [331]		
3832-C18HDSC	17.72 [450]	18.00 [457]			12.60 [320]		14.99 [381]	11.34 [288]	
3832-C20HDSC	19.69 [500]	20.00 [508]					16.96 [431]	12.60 [320]	
3832-C22HDSC	21.65 [550]	22.00 [559]			16.38 [416]		18.93 [481]	15.12 [384]	
3832-C24HDSC	23.62 [600]	24.00 [610]	8.82 [224]		16.38 [416]		20.90 [531]	13.86 [352]	18.90 [480]
3832-C26HDSC	25.59 [650]	26.00 [660]	8.82 [224]		16.38 [416]	21.42 [544]	22.87 [581]	13.86 [352]	20.16 [512]
3832-C28HDSC	27.56 [700]	28.00 [711]	8.82 [224]	11.34 [288]	16.38 [416]	21.42 [544]	24.84 [631]	13.86 [352]	21.42 [554]

* Load rating based on an 18" slides mounted in a 16" wide drawer cycled 50,000 times.
• A lateral file is wider than it is deep.

NOTE: Drawer width should not exceed slide length.
NOTE: For optimal performance, make drawer 1-1/16" [27.0 mm] less than cabinet opening. Slides may not function properly if side space is less than .50" [12.7mm].

Drawer Box Preparation

1. Drawer box width should not exceed slide length.
2. Slides will not function properly if side space is less than .50" [12.7 mm]. For optimum performance, construct drawer 1-1/16" [27.0 mm] smaller than cabinet opening.

Cabinet Member Installation

1. **Overlay drawer front:**
 - Conventional mounting, see Figure 1.
 - 32 mm system mounting, see Figure 2.
2. **Inset drawer front:** slide setback is the thickness of the drawer front plus 1/8" [3.2 mm].

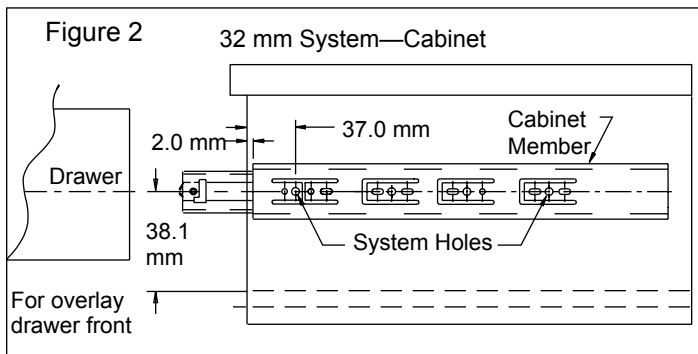
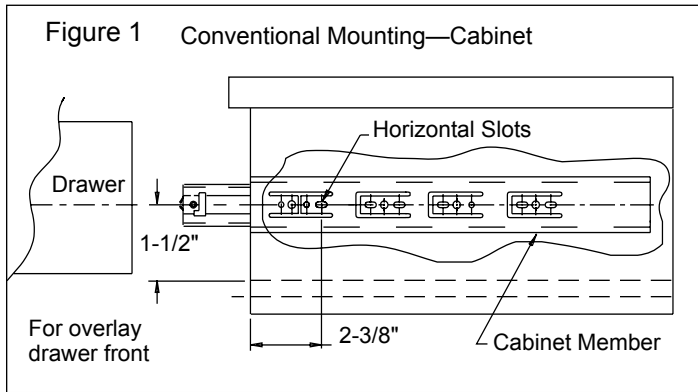

3. Use only the 32 mm system holes or the wood screw holes located at the tip of the breathing tabs. Do not use any other holes on the cabinet member for mounting (Figure 3).

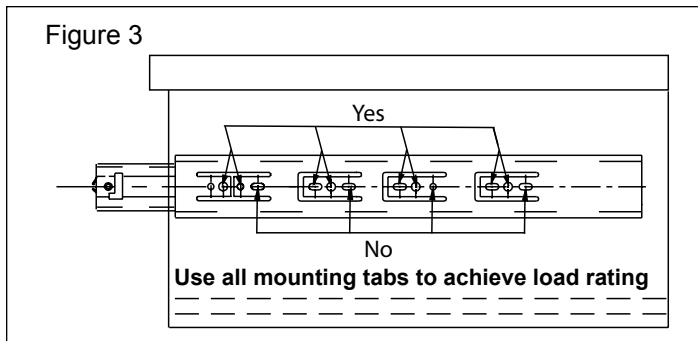

Drawer Member Installation

4. See Figure 4 for drawer member setback.
5. Install the drawer member with a screw through the cam adjuster and a screw through a hole or slot at the rear (Figure 5).

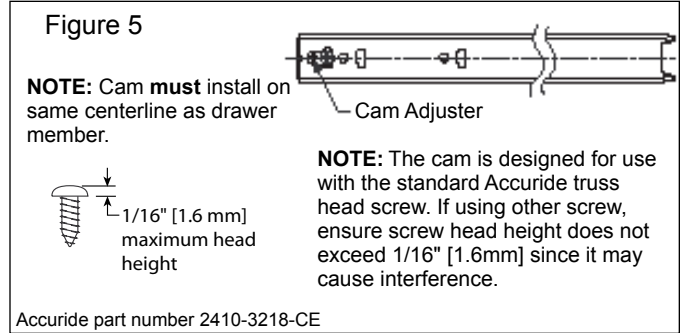
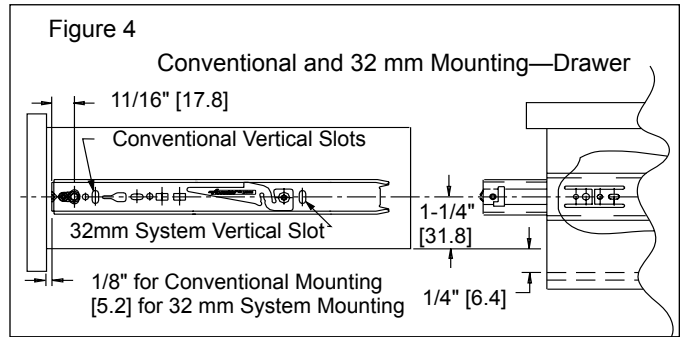

Drawer Insertion and Adjustment

6. **Make sure the ball bearing retainers in the cabinet member are fully forward.** Install drawer into cabinet. Push the drawer in until completely closed; the Self-Close mechanism will click and engage. Cycle the drawer two or three times.
7. To adjust the drawer front position, open the drawer and rotate the cam with a Phillips or Pozi screwdriver to adjust the vertical position of the drawer. Total vertical adjustment is 1/8" [3.2 mm]; +/- 1/16" [1.6 mm] from center up and down.
8. Install additional set screws to secure. Install drawer pulls or knobs.

Slide Ordering Information

Complete your slide order for Accuride models 3832SC by specifying the following:

	50	Pair	C	3832	-C18	HDSC	D
Total Required Slides	_____						
Slide Finish	_____						
Slide Model	_____						
Slide Length	_____						
Self-Close Feature	_____						
Polybag Packaging	_____						

Packaging

Distributor (D) Pack: All lengths are packaged 10 pair per box. Polybag includes one pair of slides with mounting screws.

Bulk (P) Pack: All lengths are packaged 10 pair per box. Slides and screws are ordered and packaged separately.

Optional Face Frame Brackets

Face frame brackets are ordered as a kit or in bulk. Brackets are available in clear zinc finish only. Mounting screws are not included.

To order **kits**, specify P/N 4180-0322-XE. Each kit contains: 2 front brackets, 2 rear brackets, and installation instructions. Order 1 kit per pair of slides.

For **bulk**, order 2 front brackets (P/N 4010-0516-CE) and 2 rear brackets (P/N 4080-0508-CE) per pair of slides.

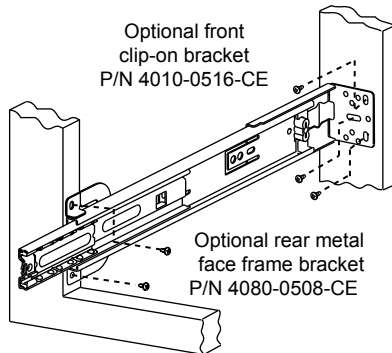

Specifications

Slide members and ball retainers: Cold rolled steel

Ball bearings: Carburized steel/acetal polymer.

RoHS compliant.

NOTE: Specifications, materials, prices, terms, and delivery are subject to change without notice.

Accuride®

ACCURIDE INTERNATIONAL INC.

12311 Shoemaker Avenue
Santa Fe Springs, CA 90670

TEL (562) 903-0200

FAX (562) 903-0208

www accuride.com

Manufacturing, Engineering, and Sales

United States • Germany • Japan • Mexico • United Kingdom • China

Copyright © 2010 Accuride International Inc. 3700-9467(1112)-MK095-R6-0711