



This product is covered by U.S. and various foreign patents issued and/or pending.

Not recommended for applications where beaded moldings are used.

Inset Face Frame Bracket Kit
Part Number 4180-0604-XE

For use with models
3132SC Self-Close
3132EC Easy-Close

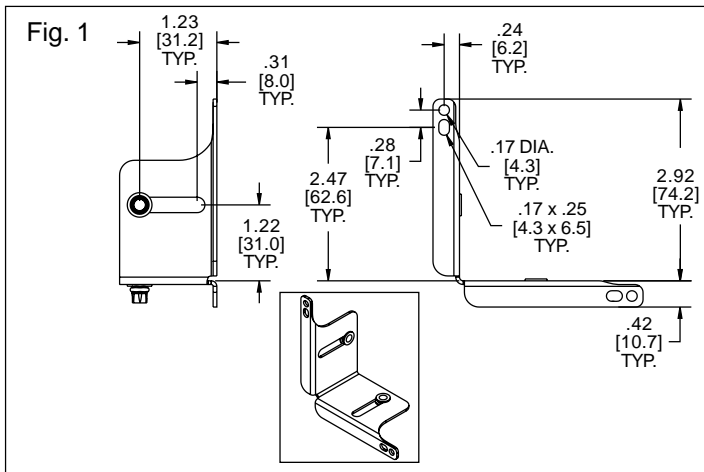

PREPARATION

For the rear face frame bracket, order kit # 4180-0560-XE separately. Refer to figure 1 of the rear face frame installation guide and attach the rear bracket to the slide.

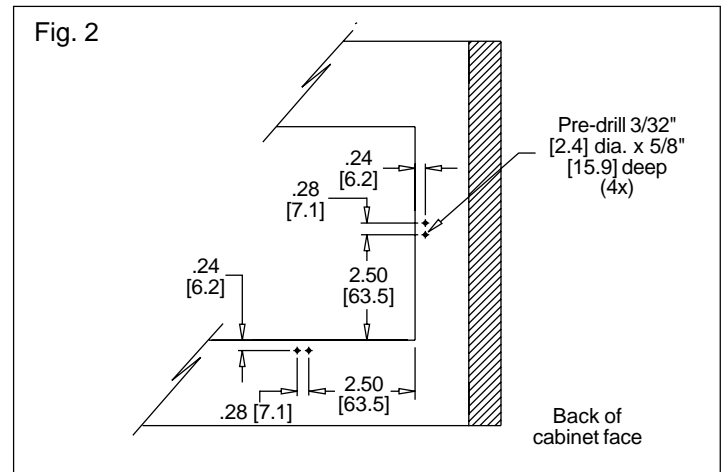

FIGURE 2

Pre-drill 3/32" [2.4] dia. holes as shown on both sides of the cabinet.

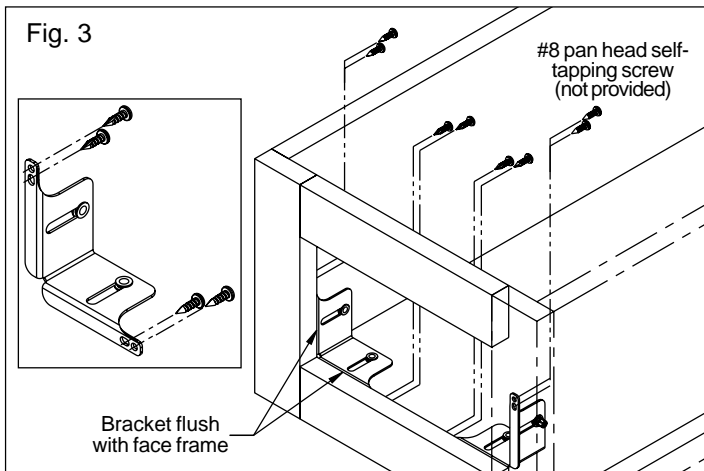

FIGURE 3

Position the inset brackets flush with cabinet's front face frame. Install using #8 pan head screws (not provided).

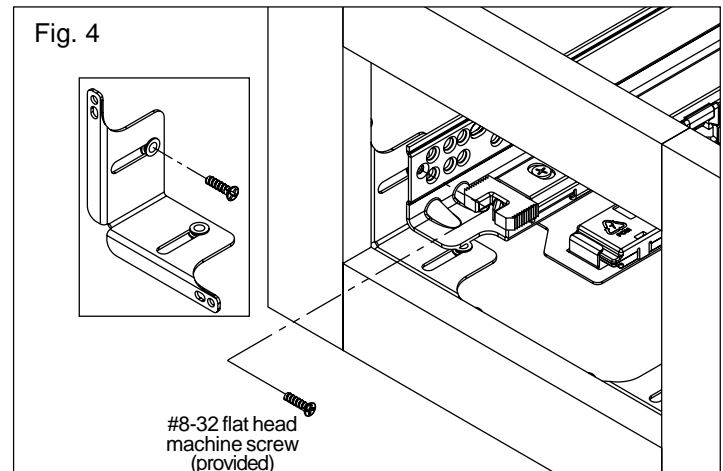

FIGURE 4

Install front of slide to the front inset bracket loosely using the #8-32 flat head machine screws that are provided in the kit.

Note: Do not tighten the screw until slide is properly positioned.

Refer back to the rear face frame bracket installation guide and follow procedures for figures 3 and 4. The inset bracket slots provide for a flush inset drawer front. Locate slides based on desired drawer front position. Tighten the 8-32 machine screw to fix the slide location and complete the installation.

Ordering/Packaging Information

Inset face frame brackets are ordered as a kit or in bulk. Kits are packaged 60 per box. Brackets are provided in zinc finish. Mounting screws to the cabinet are not included.

To order the kit, specify part number 4180-0604-XE. Each kit contains 2 inset bracket assemblies, 2 each #8-32 flat head screws and an installation guide in a polybag.

To order in bulk, specify part number 4180-0620-XE. Brackets are packed 120 each per box.



ACCURIDE INTERNATIONAL INC.

12311 Shoemaker Avenue
Santa Fe Springs, CA 90670

TEL (562) 903-0200

FAX (562) 903-0208

www accuride.com

Manufacturing, Engineering, and Sales

United States • Germany • Japan • Mexico • United Kingdom

Copyright © 2006 Accuride International Inc. Printed in U.S.A. 3700-1159(9498)-MK110-R2-0806