



This product is covered by U.S. and various foreign patents issued and/or pending.

Not recommended for applications where beaded moldings are used.

Bottom Inset Face Frame Bracket Kit
Part Number 4180-0605-XE

For use with models
3132SC Self-Close
3132EC Easy-Close

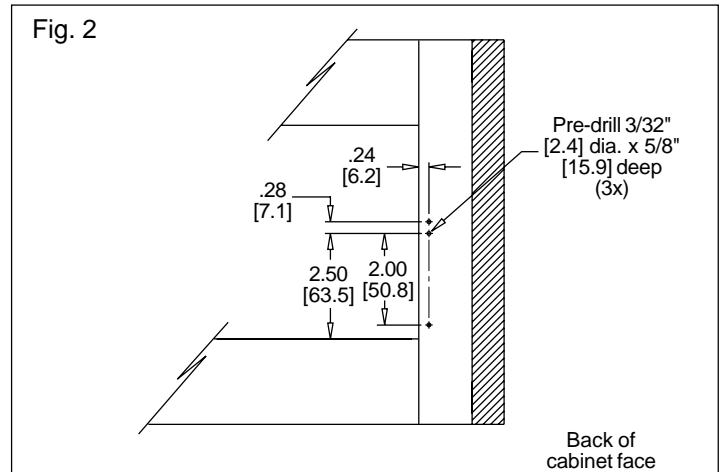
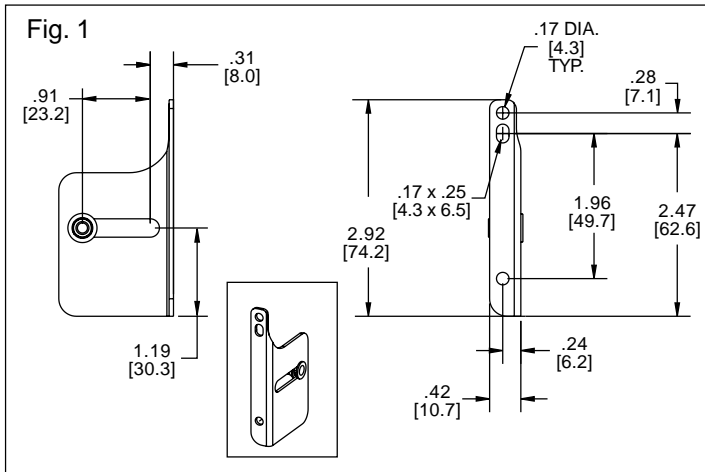

PREPARATION

For the rear face frame bracket, order kit # 4180-0560-XE separately. Refer to figure 1 of the rear face frame installation guide and attach the rear bracket to the slide.

FIGURE 2

Pre-drill 3/32" [2.4] dia. holes as shown on both sides of the cabinet.

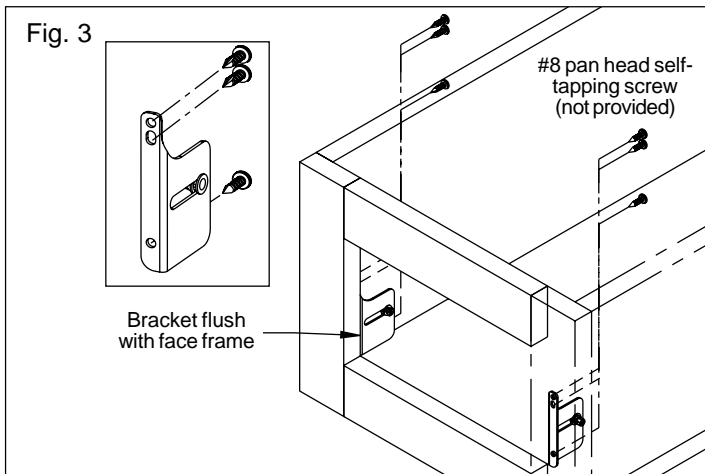

FIGURE 3

Position the inset brackets flush with cabinet's front face frame. Install using #8 pan head screws (not provided).

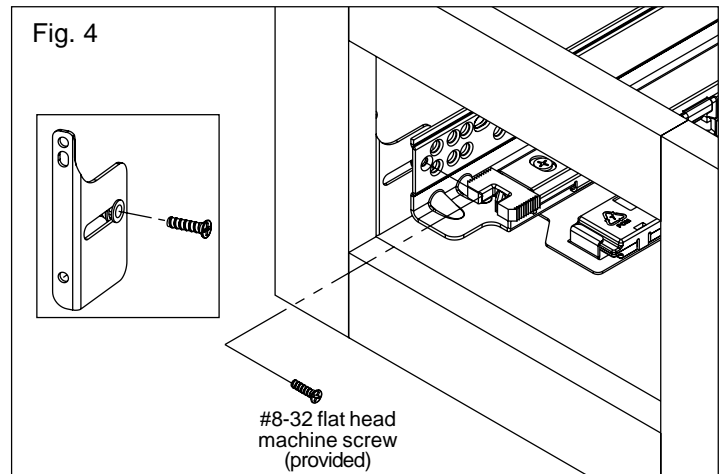

FIGURE 4

Install front of slide to the front inset bracket using the #8-32 flat head machine screws that are provided in the kit.

Note: Do not tighten the screw until slide is properly positioned.

Refer back to the rear face frame bracket installation guide and follow procedures for figures 3 and 4. The inset bracket slots provide for a flush inset drawer front. Locate slides based on desired drawer front position. Tighten the 8-32 machine screw to fix the slide location and complete the installation.

Ordering/Packaging Information

Bottom inset face frame brackets are ordered as a kit. Kits are packaged 60 per box. Brackets are provided in zinc finish. Mounting screws to the cabinet are not included.

To order the kit, specify part number 4180-0605-XE. Each kit contains 1 pair bottom inset bracket assemblies, 2 each #8-32 flat head screws and an installation guide in a polybag.



ACCURIDE INTERNATIONAL INC.

12311 Shoemaker Avenue
Santa Fe Springs, CA 90670

TEL (562) 903-0200

FAX (562) 903-0208

www accuride.com

Manufacturing, Engineering, and Sales

United States • Germany • Japan • Mexico • United Kingdom

Copyright © 2006 Accuride International Inc. Printed in U.S.A. 3700-1160(9499)-MK109-R2-0806