

**Applications:** This slide is ideal for very heavy duty applications in environments subject to corrosion.

Aluminum  
Full Extension  
Up to 882 lbs [400 kg.] Load Rating\*  
Slides Sold Individually

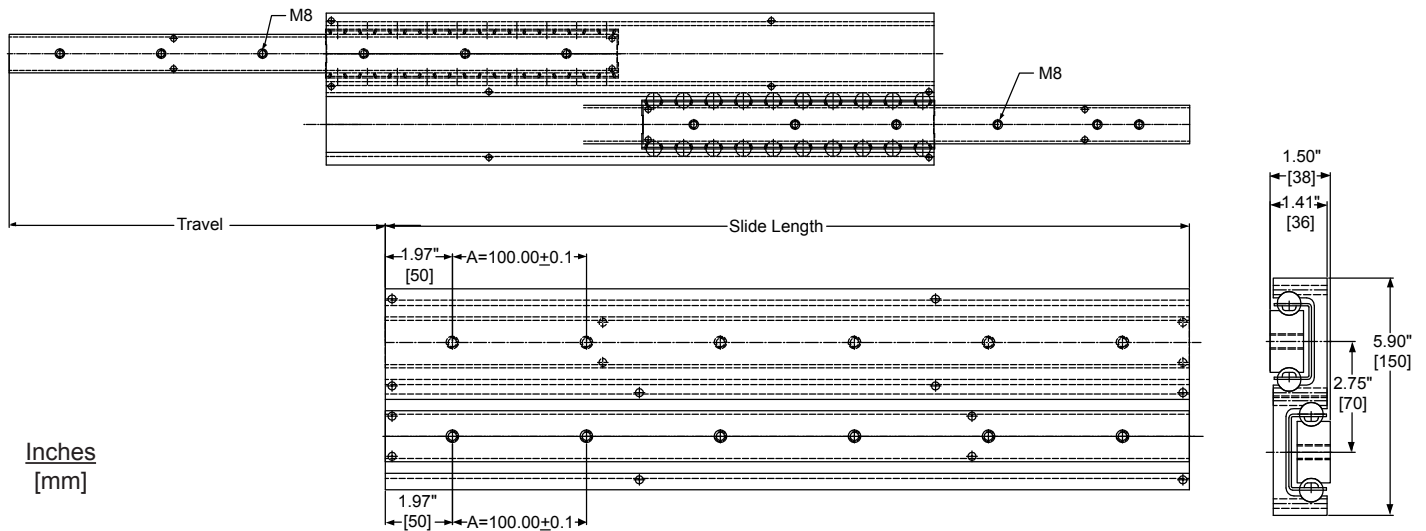

Inches  
[mm]

- Finish:** Aluminum (RoHS compliant)
- Length:** 16", 20", 24", 28", 32", 36", 40", 44", and 48"  
[400 mm, 500 mm, 600 mm, 700 mm, 800 mm, 900 mm, 1000 mm and 1200 mm] \*\*
- Travel:** Full Extension
- Height:** 5.90" [150 mm]
- Load:** Up to 882 lbs [400 kg]\*
- Side Space:** 1.50" [38 mm]
- Mounting:** Side mount/Hard mount
- Hardware:** M8 screw (Not included)

Part Number	Slide Length	Travel	A
AL4140-16	15.75 [400]	15.82 [402]	3 X
AL4140-20	19.68 [500]	21.38 [543]	4 X
AL4140-24	23.62 [600]	24.60 [625]	5 X
AL4140-28	27.56 [700]	27.83 [707]	6 X
AL4140-32	31.50 [800]	33.39 [848]	7 X
AL4140-36	35.43 [900]	36.61 [930]	8 X
AL4140-40	39.38 [1000]	39.84 [1012]	9 X
AL4140-44	43.30 [1100]	45.40 [1153]	10 X
AL4140-48	47.24 [1200]	48.62 [1235]	11 X

\* Load rating based on a pair of slides mounted 24" apart and tested at 10,000 cycles.  
\*\* The lengths indicated in inches are approximate conversions from the metric measurements.  
Please see chart above for exact dimensions.

## Installation Instructions

**!** **Important:** Accuride recommends first pre-drilling all mounting holes. Align the slide as described below to pre-drill.

1. Position the outer member flush to the cabinet or rack opening. Mount the slide member (Figure 1 and Figure 2) to the cabinet or rack using M8 screws (not included). Screws are inserted through the cabinet or rack side wall and into the threaded holes on the slide. Be sure slides are parallel.
2. Position the inner member flush to the front of the drawer or chassis. Mount the inner member using M8 screws. Screws are inserted through the drawer/chassis and into the inner member's threaded holes (Figure 3).
3. Check slide alignment by opening and closing the drawer/chassis. Any sign of binding indicates an issue with side space, alignment, or the cabinet and/or drawer are out of square. To adjust alignment, loosen the screws and adjust the slide position until movement is smooth. Retighten screws.
4. Add screws to remaining holes. **All fixing positions must be used to achieve maximum load rating.** To ensure proper slide operation, all mounting screws must be inserted so that the screws do not interfere with slide movement. Use M8 screws.

**Note:** End stop testing is 10 cycles with a load of 882 lbs. [400 kg] at 2.62 f/s [.8 m/s]. Accuride recommends additional external stops be put into place.

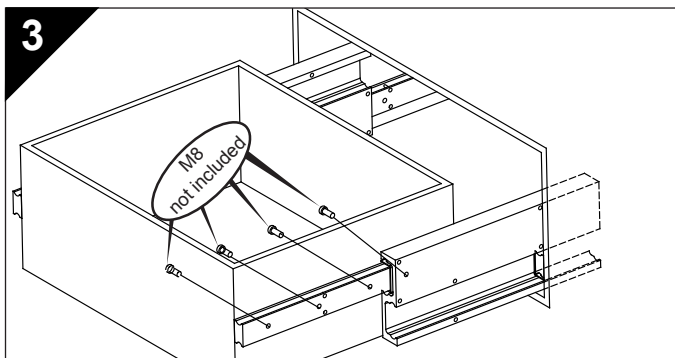
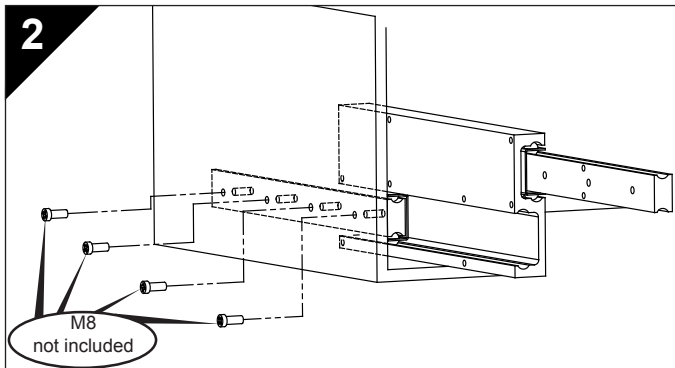
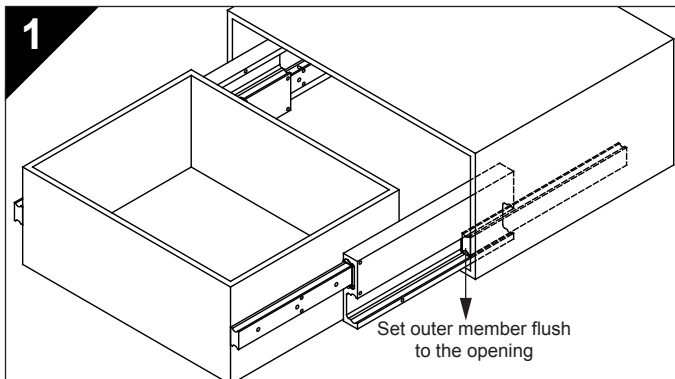

For the most current technical information please visit [www accuride.com](http://www accuride.com).

## Packaging

**Bulk Pack:** All Lengths are packaged one slide per box. Packaging includes one slide and a technical sheet.  
**Fasteners are not included.**

## Specifications

Slide Members: Aluminum  
Ball Retainers: Stainless Steel  
Ball Bearings: Stainless Steel  
Aluminum finish is RoHS compliant

**NOTE:** Specifications, materials, prices, terms, and delivery are subject to change without notice.

## Slide Ordering Instructions

Complete your slide order for model AL4140 by specifying the following information:

	1 Slide	AL	4140	-16
Total Slides Required	_____	_____	_____	_____
Slide Finish	_____	_____	_____	_____
Slide Model	_____	_____	_____	_____
Slide Length	_____	_____	_____	_____

(Fasteners are **not** included)

# Accuride

ACCURIDE INTERNATIONAL INC.

12311 Shoemaker Avenue  
Santa Fe Springs, CA 90670

TEL (562) 903-0200  
FAX (562) 903-0208  
[www accuride.com](http://www accuride.com)

Manufacturing, Engineering, and Sales  
United States • Germany • Japan • Mexico • United Kingdom • China

Copyright © 2007 Accuride International Inc. 3700-9516(1195)-MK109-N-1208