

# Designing **SLIDES** into **Electronic Enclosures**

An overview of  
electronic enclosure  
construction and  
components

*Accuride*

# Designing **SLIDES** into **Electronic Enclosures**

## **Table of Contents**

Cabinets and Rails	<b>1</b>
Cabinet Rail Construction	<b>3</b>
Chassis	<b>5</b>
Slide Selection Criteria	<b>6</b>
Bracket-to-Rail Mounting	<b>8</b>
Calculating Overall Slide and Bracket Thickness	<b>9</b>
Slide Position on the Chassis	<b>11</b>
Locating/Transferring the Slide Hole Pattern to the Chassis	<b>13</b>
Component Assembly	<b>14</b>
Bracket and Bar Nut Comparisons	<b>15</b>
Glossary	<b>16</b>

# DESIGNING SLIDES INTO ELECTRONIC ENCLOSURES

There are two main aspects to consider when designing slides into electronic enclosures: the cabinet construction and the chassis (or drawer). The attributes of these components affect the overall enclosure configuration and the selection of slides, brackets, and cable carriers.

## CABINETS AND RAILS

Cabinets vary according to manufacturer and the intended use of the cabinet. Each manufacturer may have unique rail thicknesses, shapes, materials, and placement. Since the slides mount to the cabinet rails and the chassis mounts to the slide, the variances in construction have a significant affect on the enclosure design.

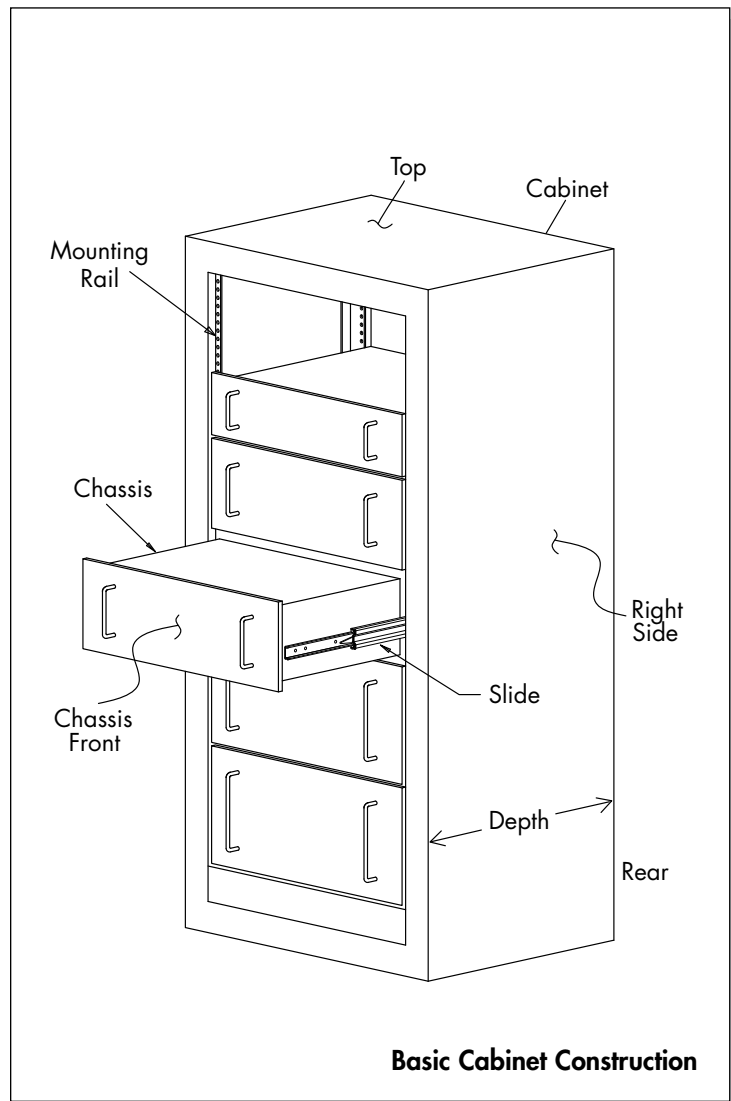

## Basic EIA cabinet construction details

- Cabinets contain four or more rails (columns, uprights or struts). The enclosure may or may not have a surrounding skin
- There are front rails, rear rails, and optional mid-rails
- Rail mounting patterns are based on standard EIA specifications
- There is no limitation on overall cabinet height.

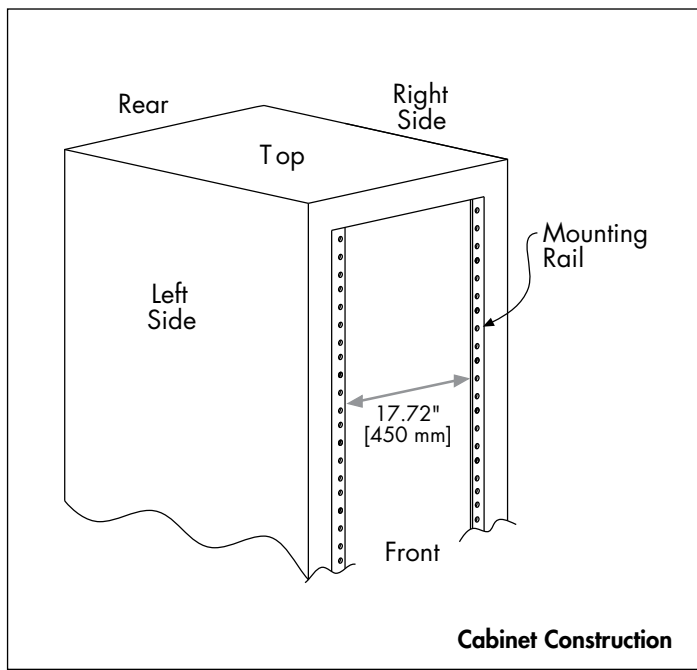
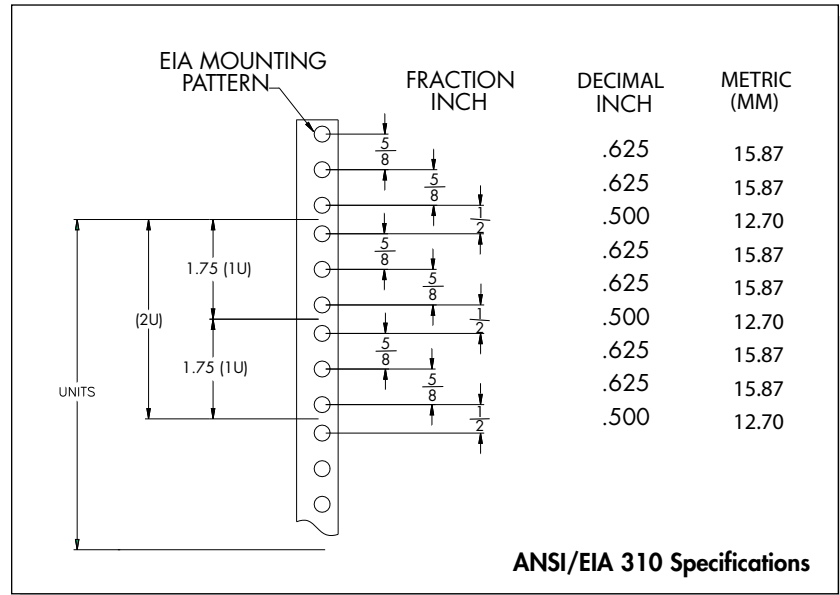

Most electronic cabinets/enclosures are based on dimensional guidelines as illustrated in the ANSI/EIA 310 Specifications.

- A standard 17.72" [450 mm] opening is the minimum width between the rails.
- Rails carry a repetitive pitch pattern of mounting holes.
- 1.75" [44.45 mm] or "1U" is the universal spacing increment and nominal height for drawers.

# CABINET RAIL CONSTRUCTION

Generally, cabinet rail construction methods fall into the following groups:

- **Non-Adjustable Rails**

Cabinet construction that provides a set distance from front rail to rear rail.

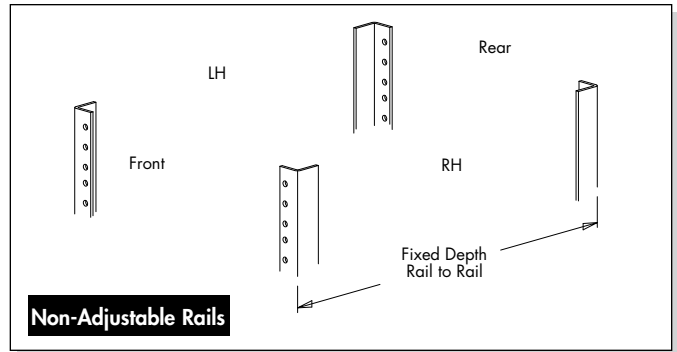

- **Adjustable Rails**

Cabinet construction that allows the end-user to relocate front and rear rails to an alternate distance from front to rear.

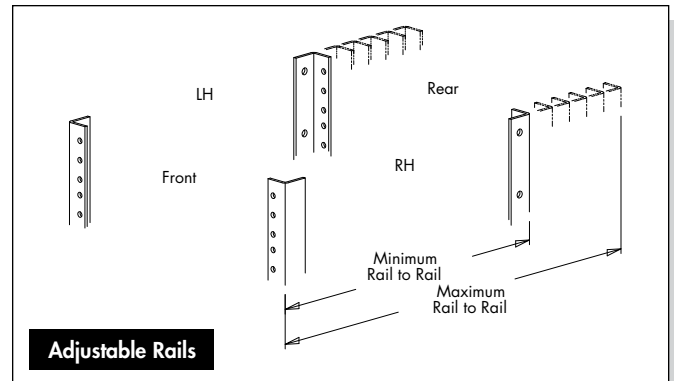

- **Mid Rails**

Cabinet construction that includes an additional set of rails, either adjustable or fixed, that provide an alternate mounting distance to accommodate short and deep slide lengths or varying chassis depths.

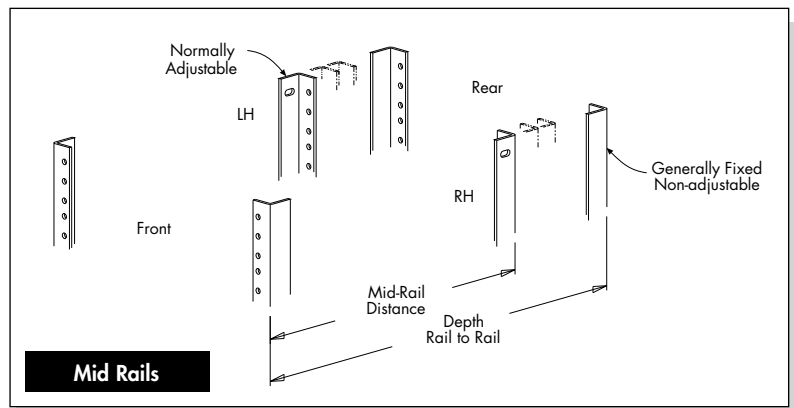

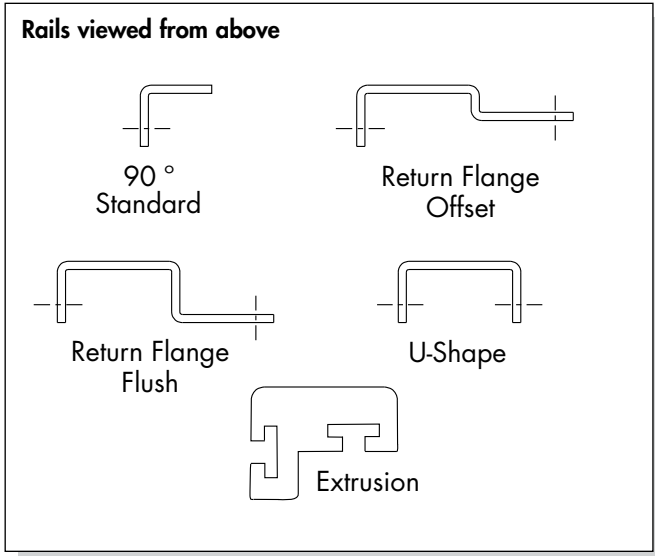

### Rail Configurations

Rails may also be referred to as columns, uprights, or struts. See the illustration at left for examples of popular configurations and the terms generally applied to these column shapes.

- 90 degree standard
- Return flange offset
- Return flange flush
- U-shaped
- Extrusion

### Mounting Holes

In addition to rail or column configuration differences, there are several types of mounting holes and locations. The mounting hole pattern is visually apparent on the front face of the cabinet column and often appears on other areas of the column as well. Generally, only one style will occur throughout the cabinet.

It is important to consult the specific supplier for exact details on the type of mounting holes offered on the cabinet.

- Through hole
- Tapped hole
- Countersunk hole
- Window/square hole

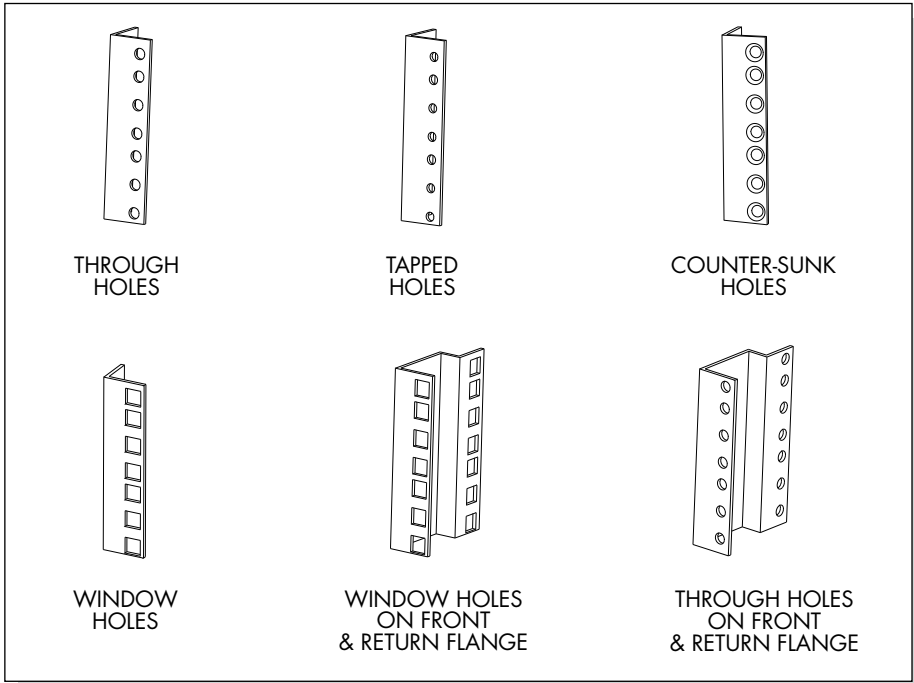

# CHASSIS

Chassis is the term for an electronics drawer. The height of a chassis is based on a nominal EIA unit increment of 1.75" [44.45 mm].

Each increment is referred to as a "U". The minimum measure of a chassis is 1U, with subsequent measures expressed as follows: 2U (3.50") [88.90 mm], 3U (5.25") [133.35 mm], etc.

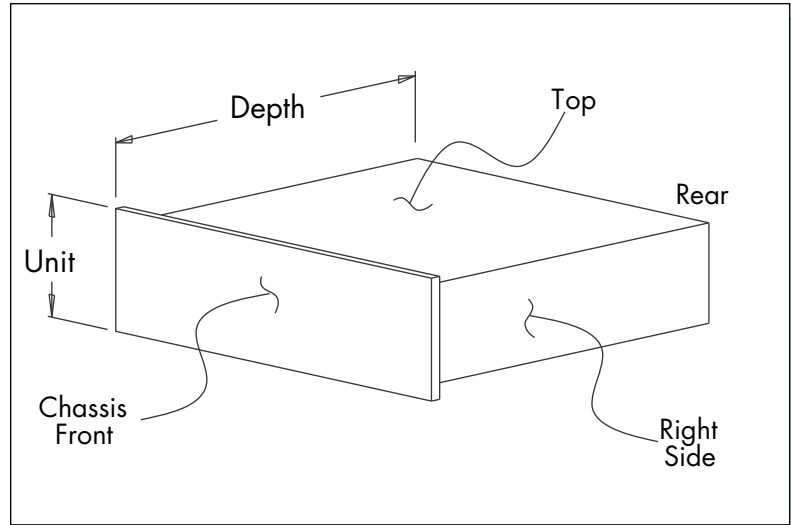

The actual height differs from the nominal height. See the chart below for specific measures.

<b>Definition of units</b>		
<b>EIA Unit</b>	<b>Nominal Height</b>	<b>Maximum Actual Height</b>
1U	1.75" [44.45 mm]	1.72" [43.69 mm]
2U	3.50" [88.90 mm]	3.47" [88.14 mm]
3U	5.25" [133.35 mm]	5.22" [132.59 mm]
4U	7.00" [177.80 mm]	6.97" [177.04 mm]
N (number of) Units	<b>N</b> Units x 1.75" [44.45 mm]	<b>N</b> Units x 1.75" [44.45 mm] – .03" [.8 mm]

## SLIDE SELECTION CRITERIA

Selecting the correct Accuride slides and bracketry is based on the following criteria:

- Height of drawer
- Anticipated chassis load
- Amount of chassis travel
- Overall depth of cabinet
- Mounting rail-to-rail distance
- Slide-to-cabinet mounting bracketry
- Accessories on slide (locking, disconnect, hole pattern)

### Anticipated Chassis Load

Identifying the chassis load will narrow the range of slide models suitable to the application.

Slide load ratings are based on **dynamic** loading, which is continuous motion both out and into the cabinet.

- Load ratings for slides in electronic enclosure applications are based on 2,000 cycles
- One cycle is considered the distance from fully closed to fully opened to fully closed in one motion.
- The cycle speed is generally based on 10–12 cycles per minute.

**As a margin of safety, when fully extended, all Accuride slides accept a static overload of 2 times the indicated load rating.**

Consult Accuride for additional test information for shock and vibration, momentary, seismic, or other special requirements.

### Amount of Chassis Travel

Determining the distance the chassis will be required to travel (the relationship between the back of the chassis and the front of the cabinet) will help establish whether a two- or three-section slide is best suited for a particular application.

Two-section slides provide **3/4 travel**. In other words, the drawer opens approximately three-quarters of the total slide length.

Three-section slides offer **full extension** or **over travel**; the drawer opens the same amount or more than the length of the slide.

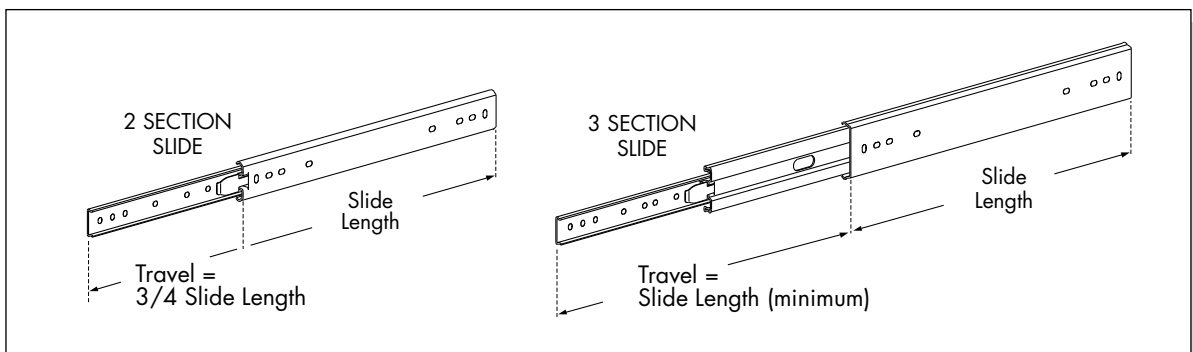

## Overall Cabinet or Enclosure Depth

The depth of the cabinet determines the slide length and corresponding travel required for the application. The following factors should be considered when measuring:

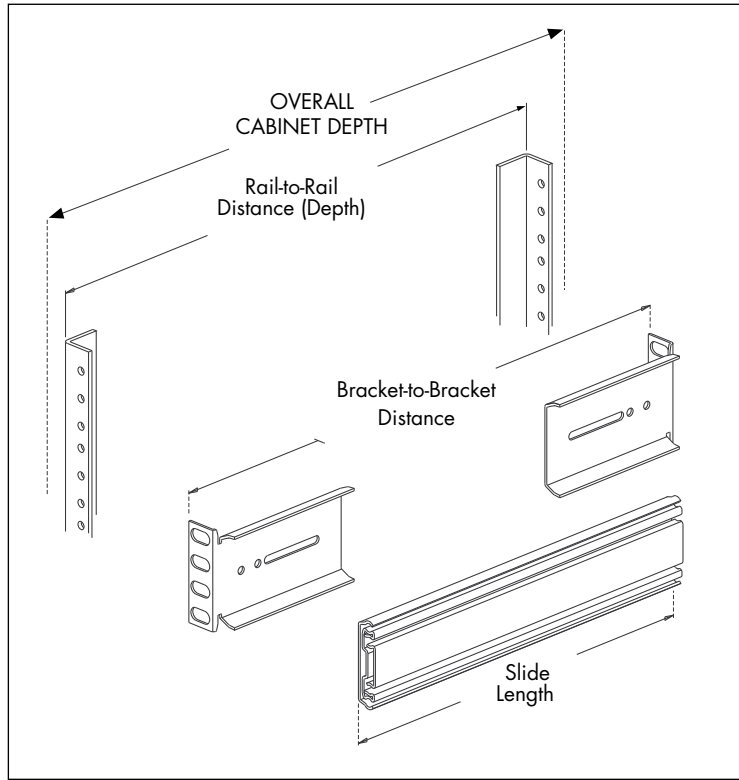

- Enclosure depth is measured from the front of the cabinet to the rear. It is greater than the *mounting rail distance*, which is measured from the front rail to the rear rail.

*NOTE: Rail-to-rail distance can be measured from outside to outside or inside to inside of rail surfaces.*

- If mounting to a mid rail, the distance will be less than the distance from the front rail to the rear rail.
- A wide variation of cabinet depths and rail-to-rail distances exist. Consult cabinet manufacturer for the exact dimensions of the cabinet.

## Slide-to-Cabinet Mounting Bracketry

Accuride provides several lengths of brackets to meet specific cabinet mounting depths. Many of the Accuride brackets can be installed at a distance less than or greater than the slide length.

*Extension* brackets accommodate a greater mounting distance beyond the slide length.

Screws are inserted through the brackets and rails and are fully tightened using an accessory bar nut.

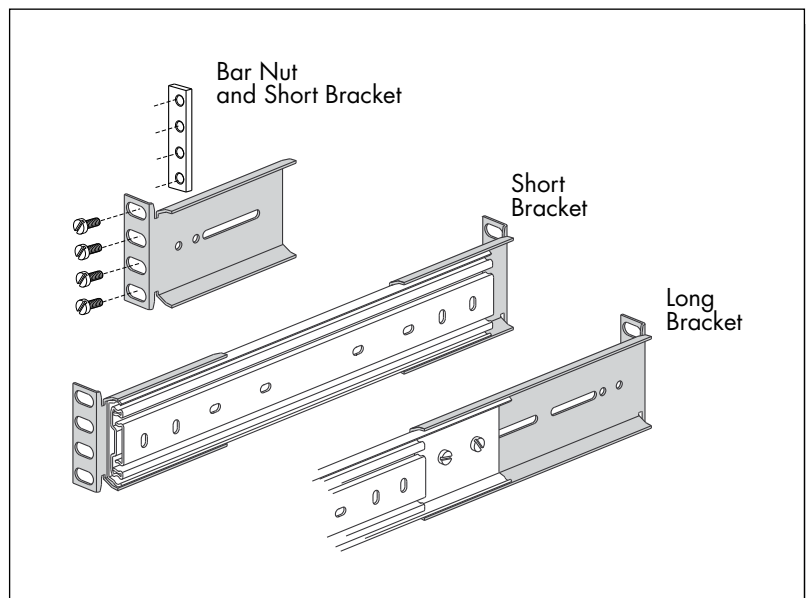

# BRACKET-TO-RAIL MOUNTING

The chart below outlines which side of the cabinet rail surface the bracket should be mounted according to the EIA rail style and accessories used.

EIA Rail Style	Mounting	Accessory	Mounting Rail Surface
Tapped	Bracket	None	Outside
Through Hole	Bracket	Bar Nut	Inside or Outside
Through Hole	Bracket	Clip Nut	Outside
Window	Bracket	Bar Nut	Inside or Outside
Window	Bracket	Clip Nut	Outside
Window	Bracket	Cage Nut	Outside

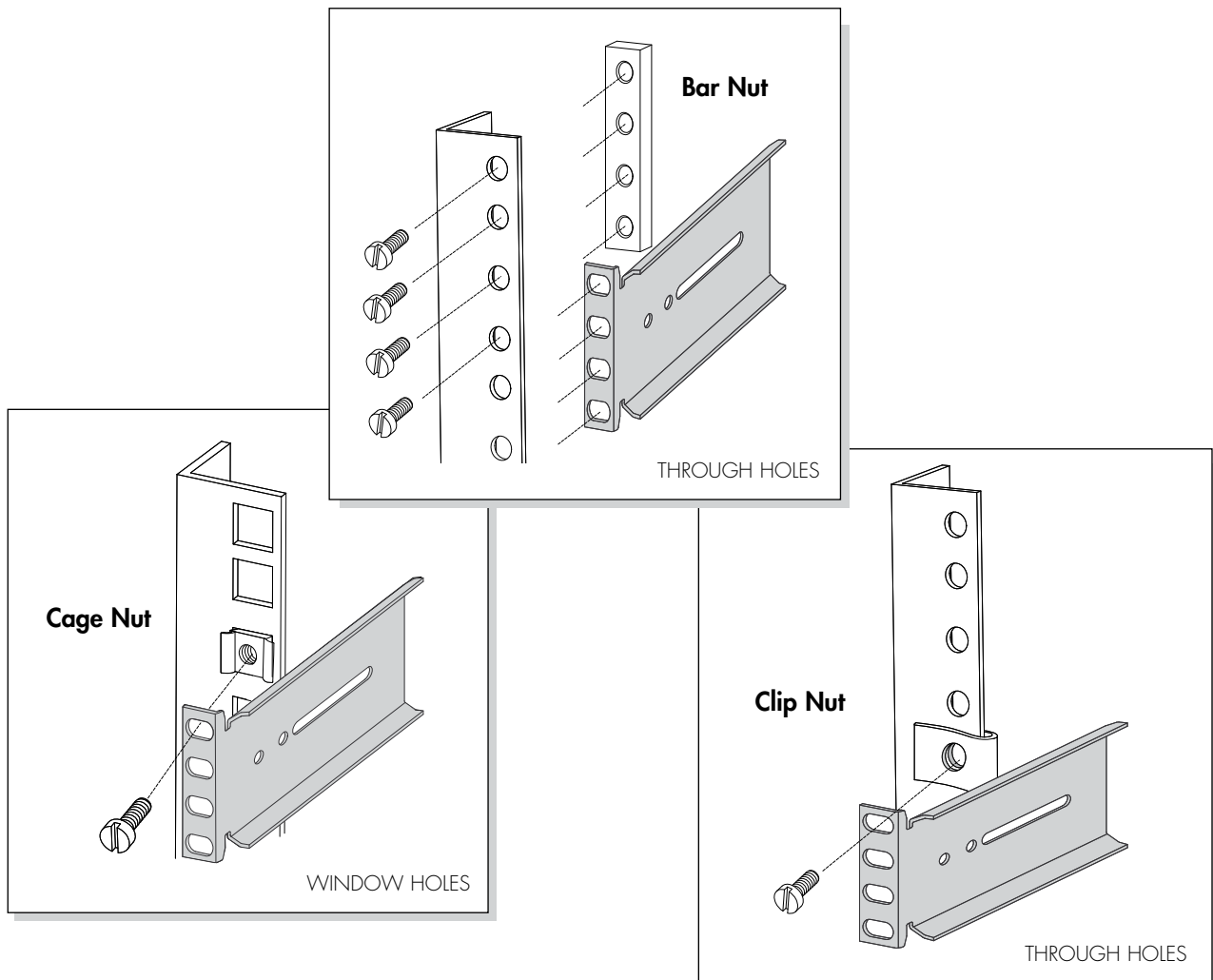

## CALCULATING OVERALL SLIDE AND BRACKET THICKNESS

The Accuride slide is the link between the cabinet and chassis; therefore accurate width dimensions are mandatory for proper slide movement and installation. It is important to remember that adding mounting brackets increases the overall slide width.

There are two crucial calculations required to determine the slide width suitable for the application:

### **Functional Space:**

The area between the rail and the chassis side. Include the overall slide thickness, or extending slide member thickness *plus* the bracket thickness.

### **Available Space:**

The area within the cabinet to mount non-moving portions of slides and/or brackets.

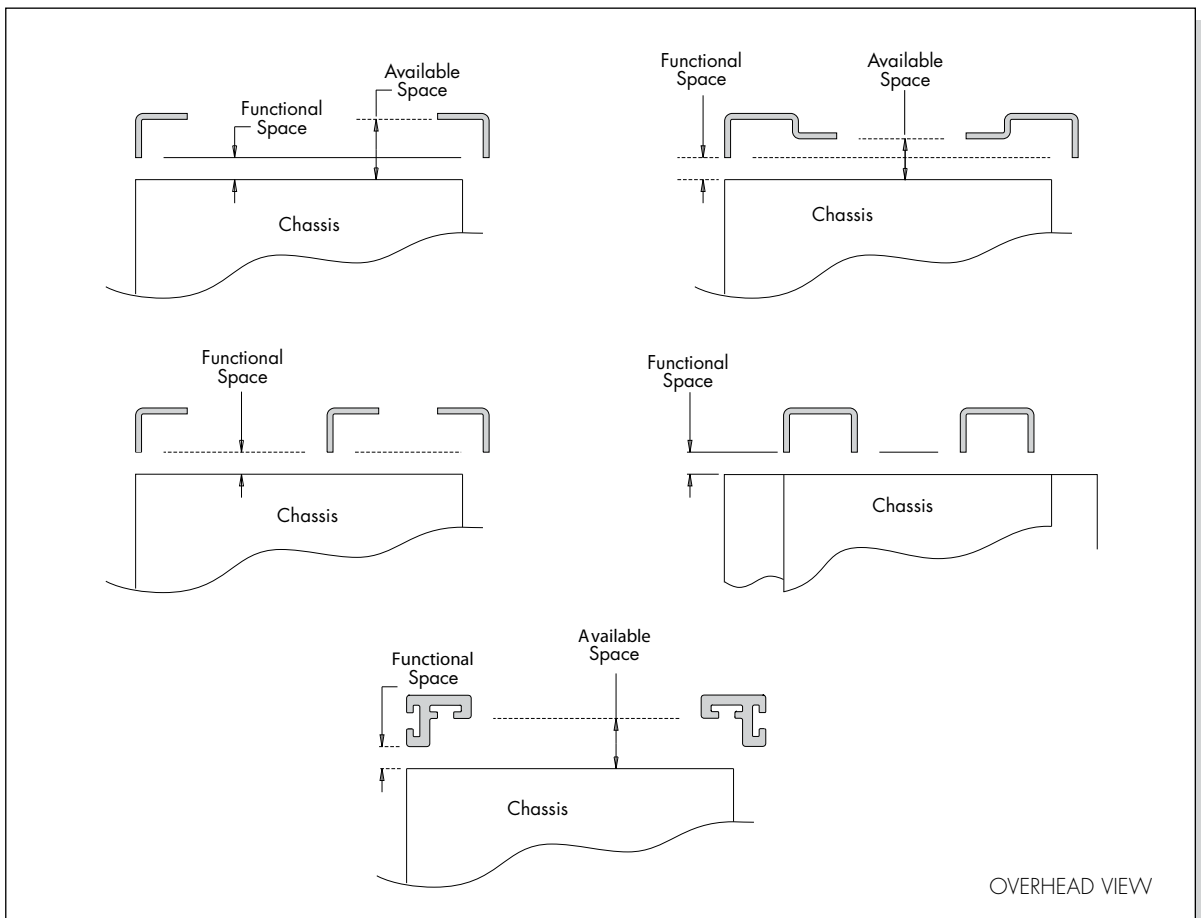
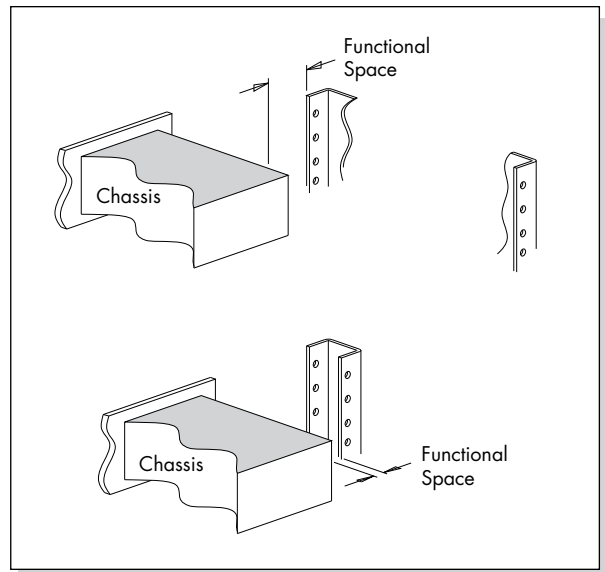

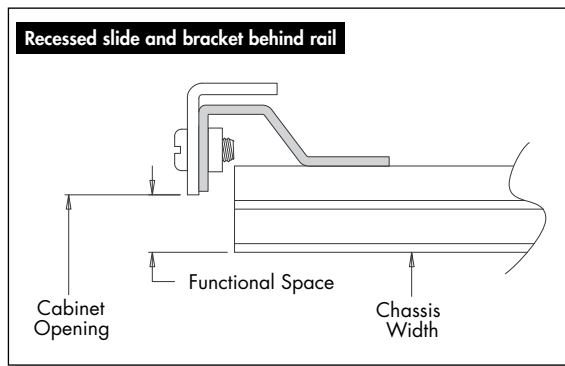
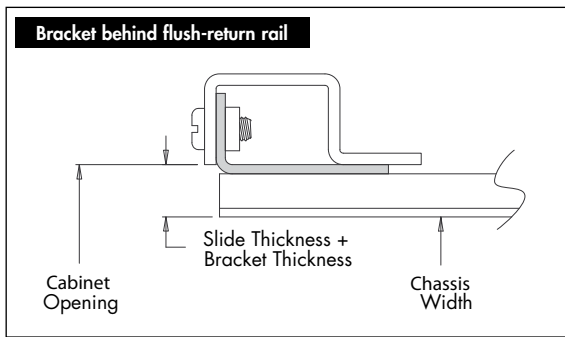
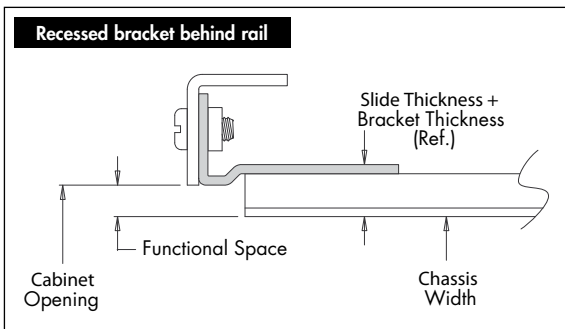
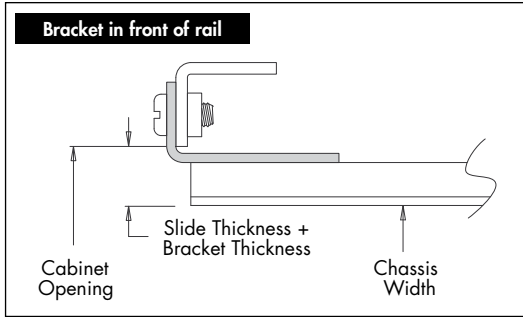
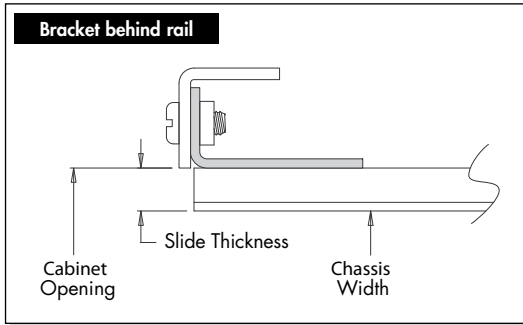

The drawings at left show several mounting configurations from an overhead perspective. This viewpoint demonstrates how to calculate chassis widths, evaluate slide thicknesses, and verify bracket installation.

- Bracket behind rail
- Bracket in front of rail
- Recessed bracket behind rail
- Bracket behind flush-return rail
- Recessed slide and bracket behind rail

If some component dimensions are known, the space available for the remaining components may be determined:

IF KNOWN	MEASURE DETERMINED
Slide width and cabinet opening	Chassis width
Chassis width and cabinet opening	Slide width and bracket thickness
Cabinet opening	Chassis width and slide width



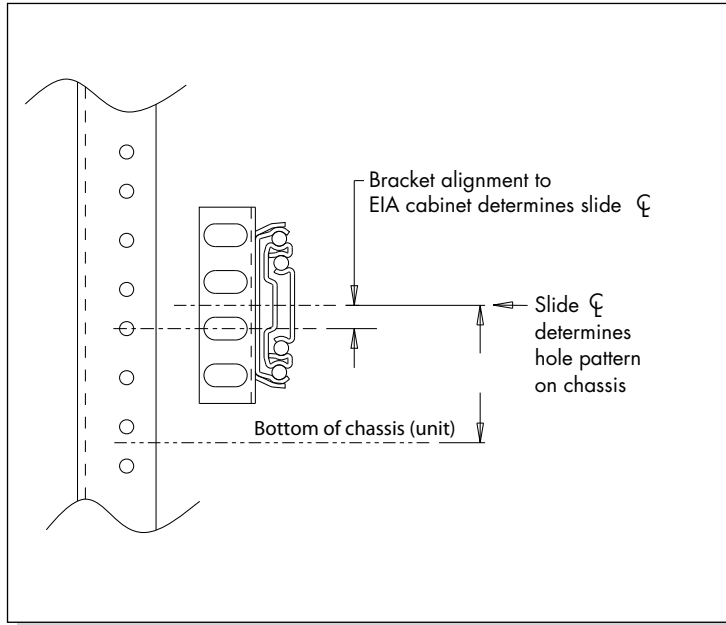

In some cases, one element of the slide installation is known, and this determines slide positioning.

- The bracket alignment to the EIA cabinet determines the slide centerline (C).
- The EIA cabinet pitch pattern determines the slide centerline.
- The location of the slide centerline determines the bracket alignment to EIA pattern on the cabinet.
- The slide centerline determines hole pattern on chassis.

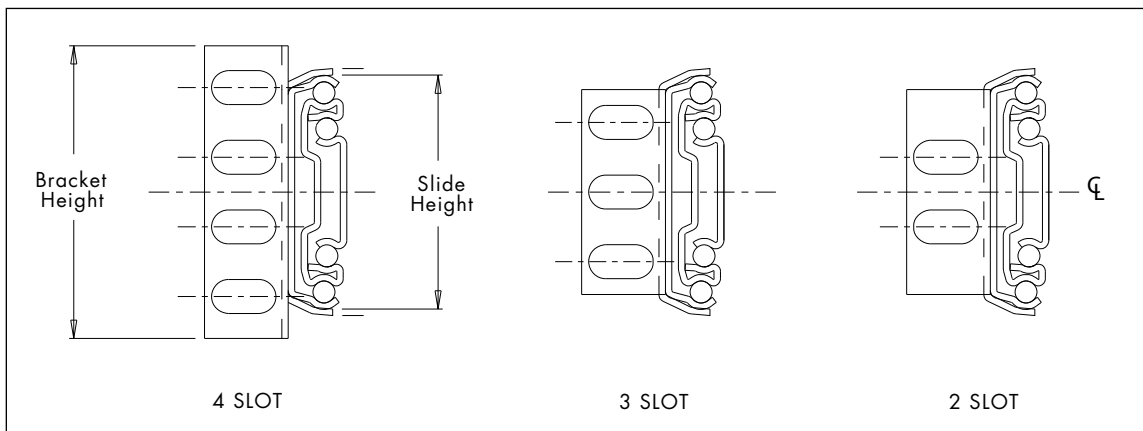

# LOCATING/TRANSFERRING SLIDE HOLE PATTERN TO CHASSIS

The following illustrations assume the chassis front panel contacts the cabinet structure. Slide bracket placement and use of hardware will determine exact dimensions.

Determining the hole pattern from slide to chassis is calculated when the slide is fully closed or when the chassis is in its final closed position. The use of hardware with or without washers plays an important role in determining the fully closed position of the chassis relative to the cabinet's front rails. If washers are used, be sure to

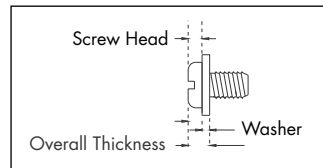

include the washer thickness dimension in your overall distance when determining the first chassis hole location.

Follow the guideline that matches your planned installation to obtain first chassis hole dimension. Refer to the product technical sheets for the remaining mounting hole locations.

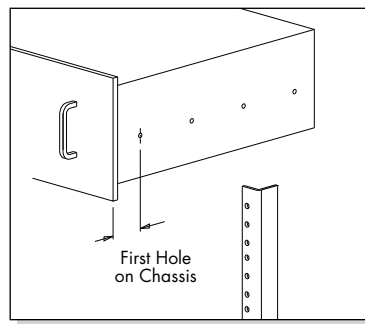
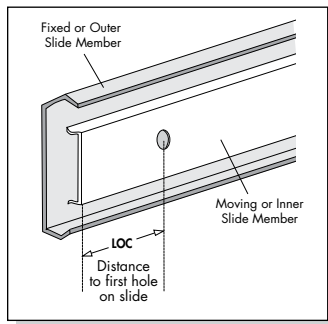

## Bracket mounted behind or in front of rail

### Fastening screw contacts back of chassis front panel (fig. A)

Front panel thickness + screw head thickness + cabinet rail thickness + distance to first slide mounting hole location.

### Mounted with a flat-head screw or other flush type (fig. B)

Front panel thickness + cabinet rail thickness + distance to first slide mounting hole location.

### Bracket in front of rail, slide and bracket aligned (fig. C)

Front panel thickness + screw head thickness + distance to first slide mounting hole location.

## Bracket mounted in front or behind rail with recessed brackets

### Recessed style bracket mounted in front of rail (fig. D)

Front panel thickness + screw head thickness + .45" [11.43 mm] + distance to first slide mounting hole location.

### Screw head contacts front panel, bracket is recessed behind rail (fig. E)

Front panel thickness + screw head thickness + cabinet rail thickness + .19" [4.83 mm] + distance to first slide mounting hole location.

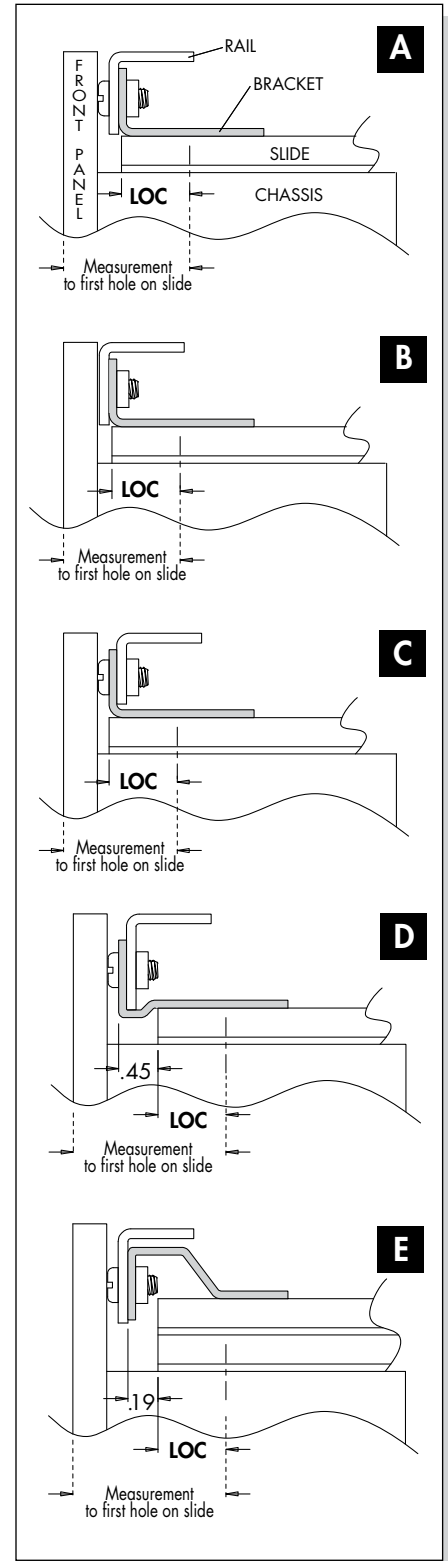

# COMPONENT ASSEMBLY

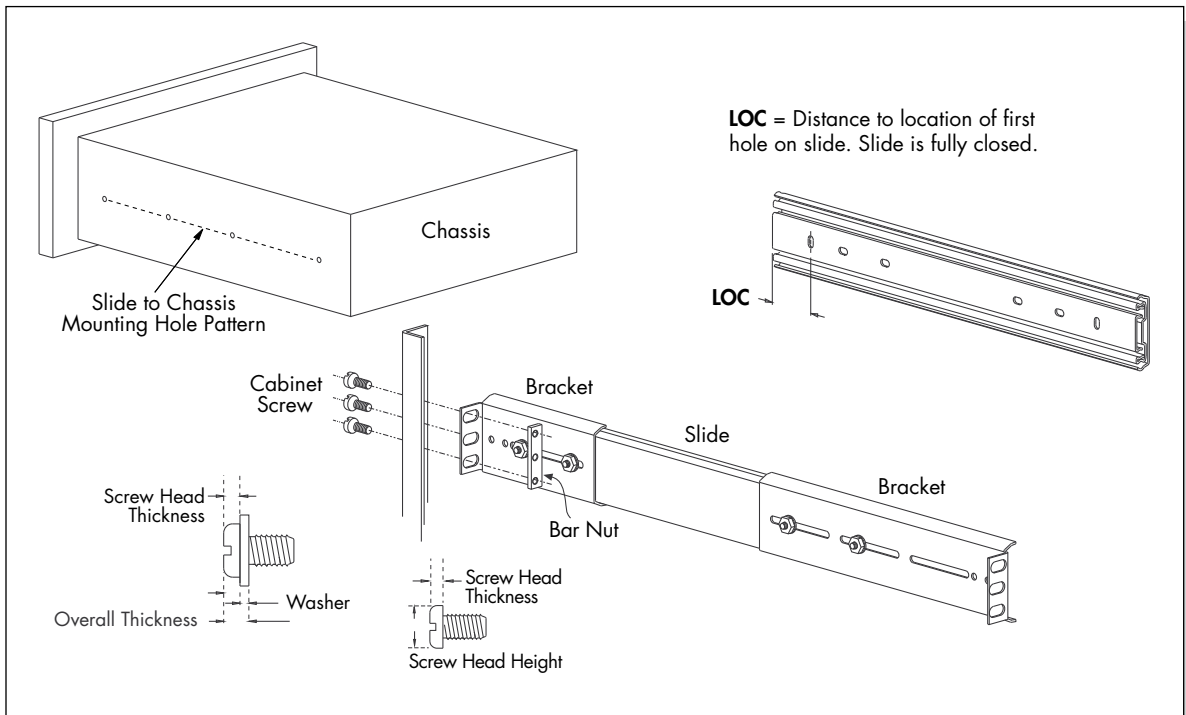

## Mounting Accessories

Typical hardware for EIA packaging is shown. Due to differences in cabinet construction, not all hardware styles are shown.



# BRACKET AND BAR NUT COMPARISONS

Accuride provides several mounting brackets and bar nut accessories to meet specific locations on the EIA cabinet. The use of 4-slot, 3-slot, and 2-slot mounting brackets and the companion bar nut selection provide a wide range of mounting possibilities. Consult Accuride technical sheets for dimensions.

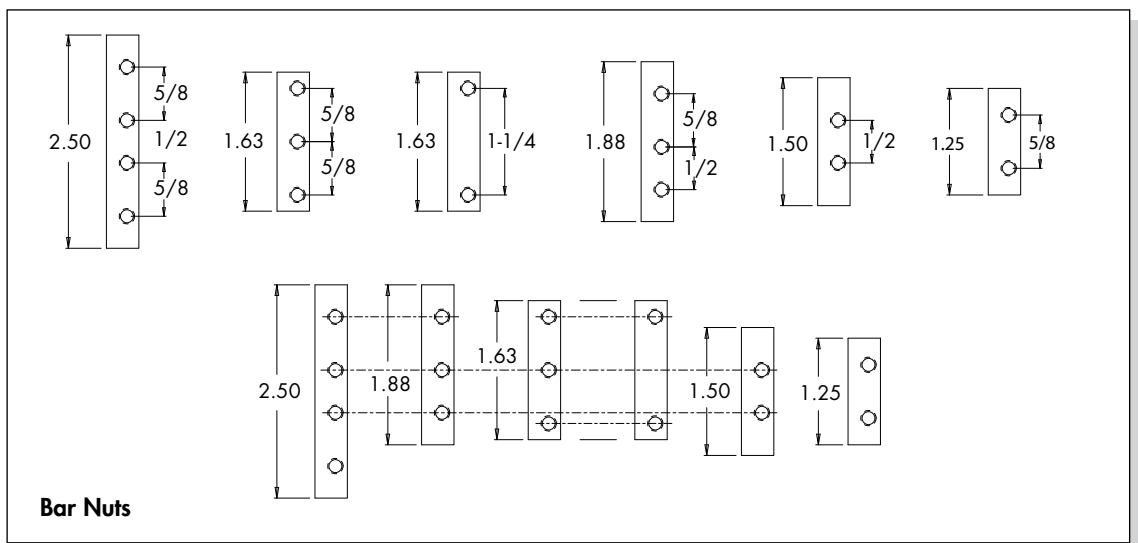
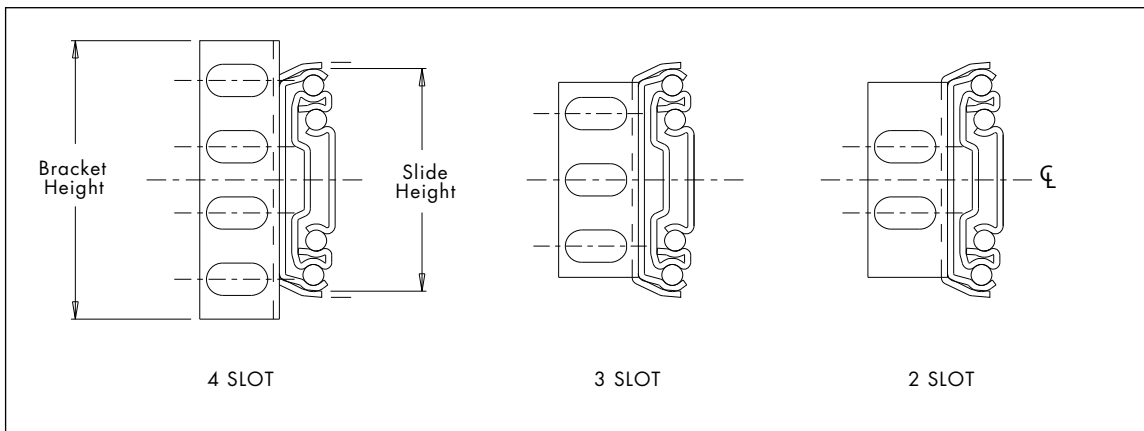
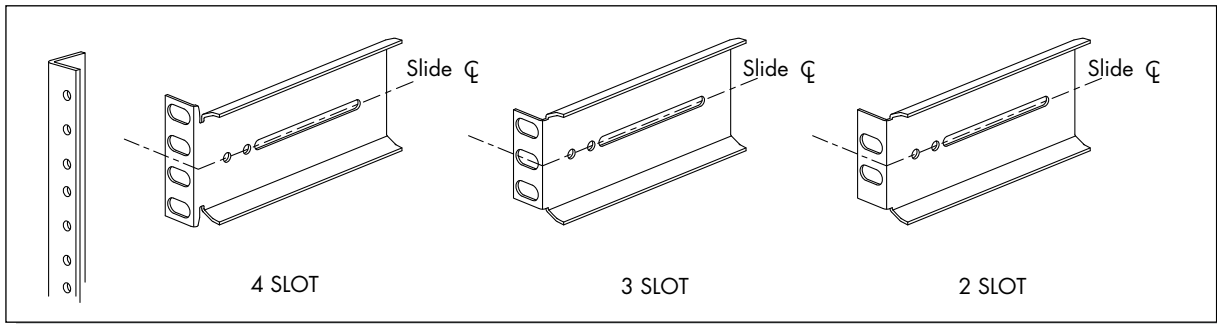

## GLOSSARY:

### Cabinet Width

The outside dimension (side to side) of a cabinet or enclosure.

### Panel Width

The outer dimension of the front mounting rails, which is greater than the clear opening between rails.

### Cable Carrier

An accessory item to support and manage wiring behind a chassis when it is withdrawn or inserted into the cabinet.

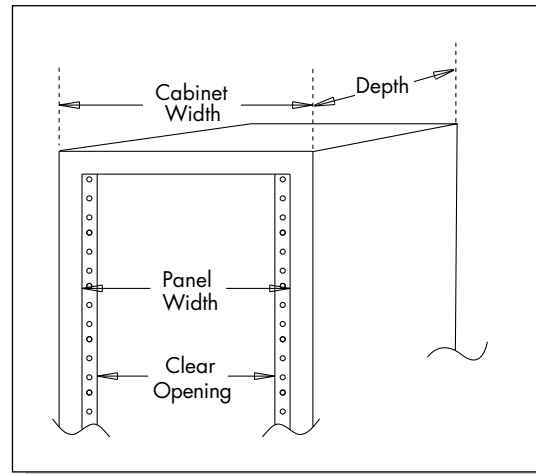

### Clear Opening

The innermost dimension between the front mounting rails.

### Chassis Front Panel

Also known as panel width. Generally greater than the chassis width.

### Depth

The front to rear dimensions of a cabinet or enclosure.

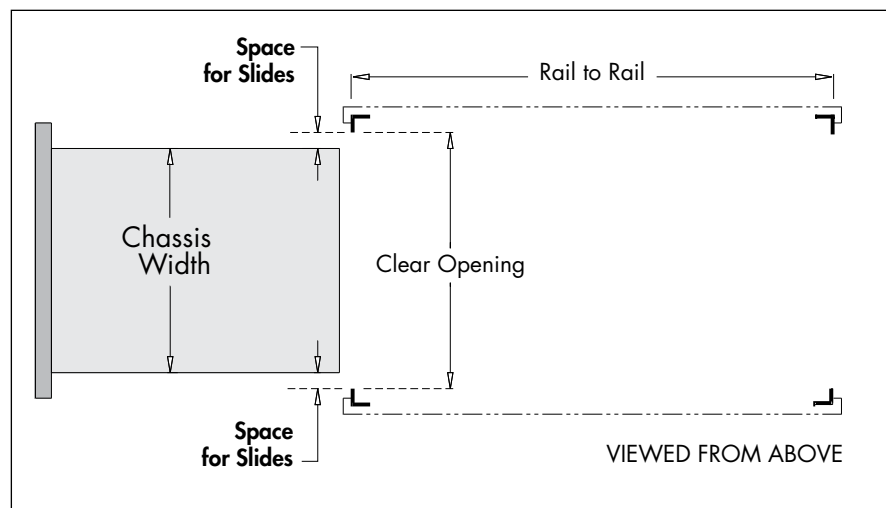

### Chassis

A universal term for an electronics drawer; also known as the unit, drawer, module, device, stack equipment, system.

### Front Panel or Bezel

The front facade of the chassis.

### Front Panel Thickness

Distance from front of cabinet rail to front end of chassis.

### Cabinet Rail Upright

Also known as mounting rail, column, strut, upright.

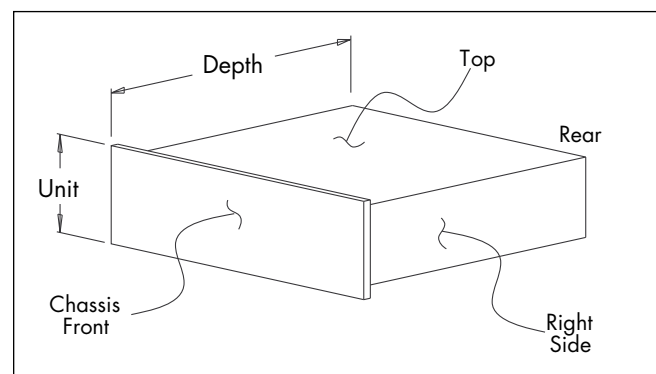

## GLOSSARY:

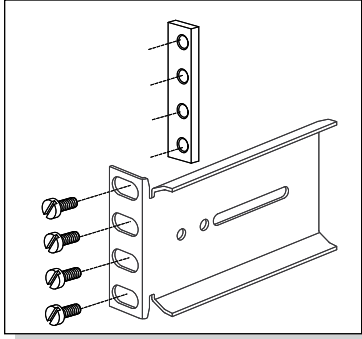

### Cabinet Mounting Screws

Hardware that attaches the slide brackets to the rails.

### Slide

Sliding mechanism that serves as link between the enclosure and chassis. Also known as rail, glide, track, runner, chassis member, or suspension.

### Slide Mounting Bracket

Attachment device between the slide and cabinet.

### Bar Nut

Threaded accessory used in place of hex nuts and washers.

### Loc

The distance to the first mounting hole available on the moving or inner slide member.

$\text{C}$  – The slide centerline

### U (unit)

Incremental measure of 1.75" [44.45 mm].

### Universal Cabinet Pattern

Mounting holes on cabinet rails in a repetitive series as follows: 1/2", 5/8", 5/8", 1/2" 5/8", 5/8", [12.7, 15.8, 15.8, 12.7, 15.8, 15.8 mm].

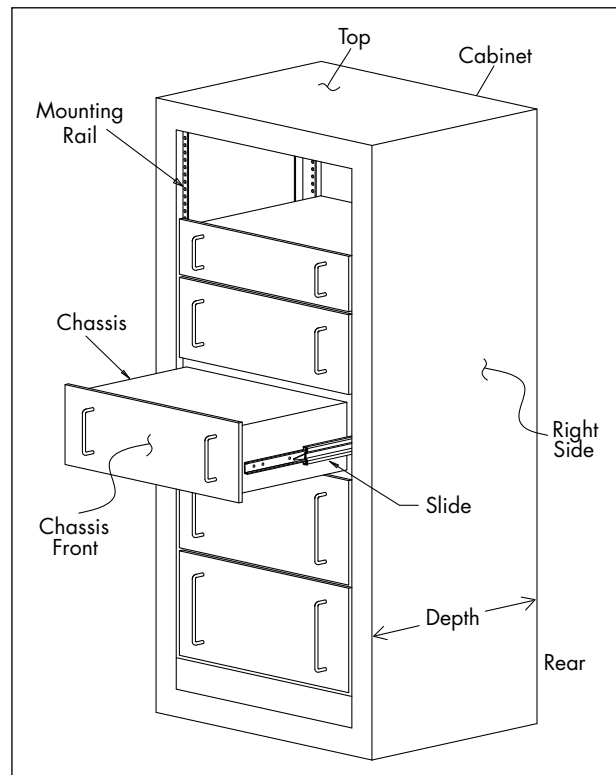
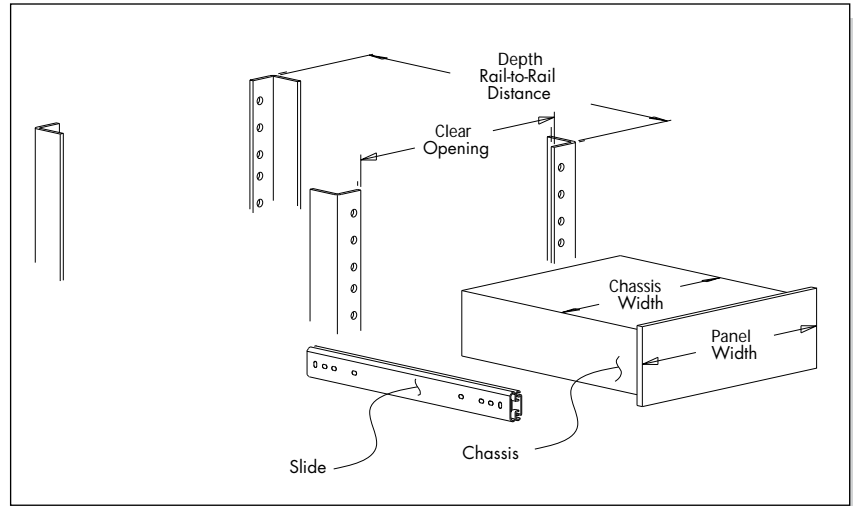



## ACCURIDE INTERNATIONAL INC.

### **North America**

INTERNATIONAL HEADQUARTERS  
12311 Shoemaker Avenue  
Santa Fe Springs, California 90670  
562 903-0200 Telephone  
562 903-0208 Fax  
[www accuride.com](http://www accuride.com)

Calle Circuito Norte No. 6  
Parque Industrial Nelson  
Mexicali, B.C., C.P. 21395 Mexico

### **Europe**

Postfach 1464  
Werner - Von Siemens - Strasse 16-18  
65582 Diez/Lahn  
Germany  
(49 64 32) 6 08-0 Telephone  
(49 64 32) 6 08-20 Fax  
[www accuride-europe.com](http://www accuride-europe.com)

Liliput Road  
Brackmills Industrial Estate  
Northampton, NN4 7AS  
United Kingdom  
(441) 604-761111 Telephone  
(441) 604-767190 Fax  
[www accuride-europe.com](http://www accuride-europe.com)

### **Asia**

Accuride Japan Co., Ltd.  
44 Minami-asaji Iwata Yawata-shi  
Kyoto, Japan  
81-75-983-7500 Telephone  
81-75-983-9500 Fax  
[www accuride.co.jp](http://www accuride.co.jp)

Accuride International Suzhou Co. LTD  
No. 178, Suhong East Road  
Suzhou Industrial Park  
Jiangsu Province, China 215026  
86-512-62731200 Telephone  
86-512-62833993 Fax  
[www accuride.com.cn](http://www accuride.com.cn)