



MODEL 115RC

APPLICATIONS: Provides guidance, support, movement or positioning for screens, panels, boards, and components used in medical apparatus, machinery, and manufacturing equipment.

MODEL 115RC

Linear Motion Track System
 Aluminum Track
 Re-circulating Ball Carriages
 Up to 265 lb. [120 kg] Load Capacity

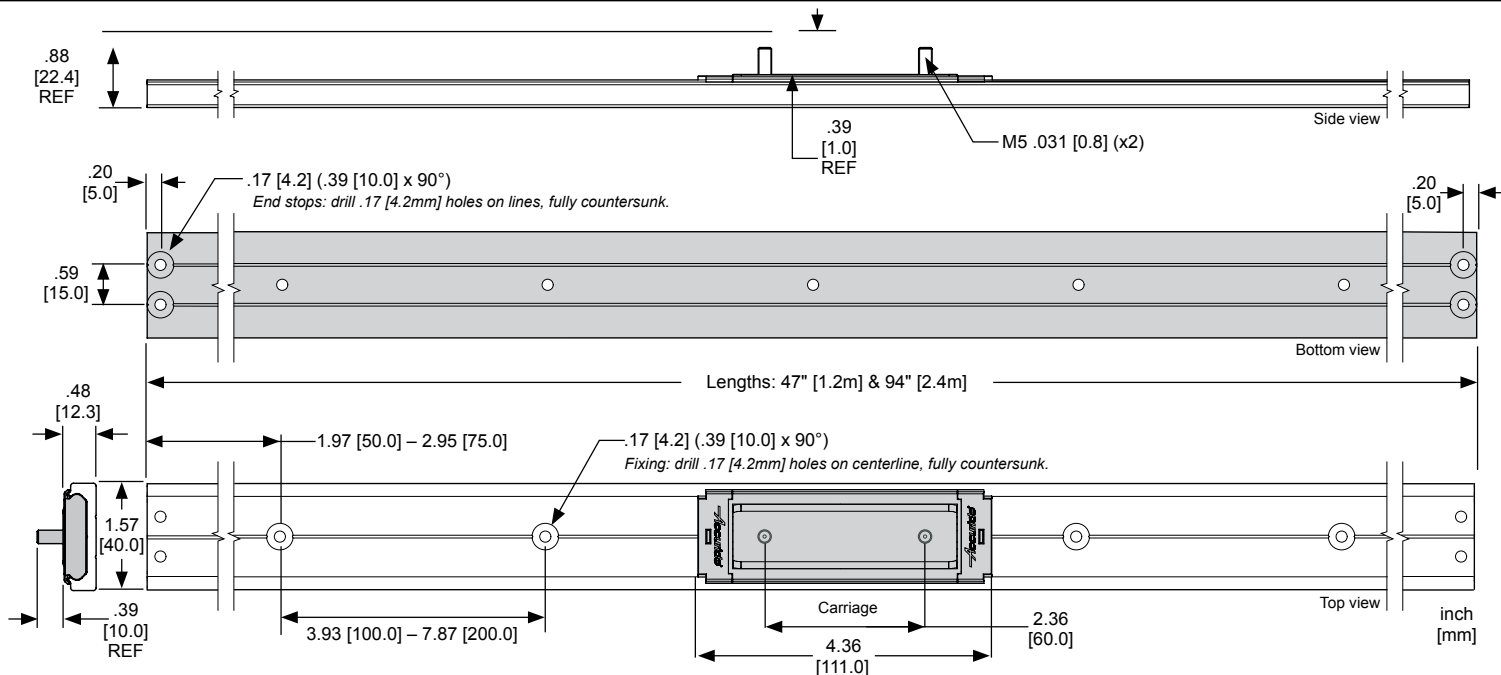

- Track material** Aluminum 6000 series
- Track length** 47" [1.2m] & 94" [2.4m]
- Ball carriages** Stainless steel and nylon
- Ball bearings** Stainless steel or polymer
- Load rating** Up to 265 lb. [120 kg]

- Mounting** Side, flat, or vertical*
- Hardware** M4 countersunk screw
4mm countersunk wood screw (not included)



* Vertical mounting should be used only for non-load bearing applications.

Load Rating

The load bearing capacity is based on the type and number of carriages. Due to the extensive variety of applications and possible orientations, we recommend that customers test this product to their specific requirements. This product is not recommended for high-torque applications.

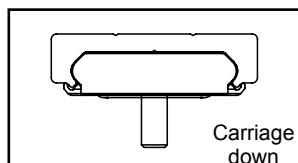
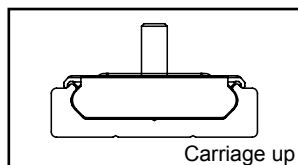
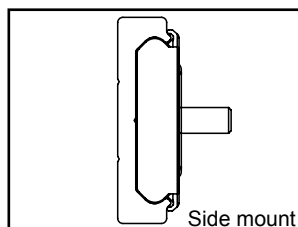

Side Mount			
SS0115-CASSRC Stainless Steel Ball Carriage	Load Rating	CB0115-CASSRC Polymer Ball Carriage	Load Rating
x1	110 lbs.	x1	65 lbs.
x2	200 lbs.	x2	120 lbs.
x3	265 lbs.	x3	160 lbs.
Flat Mount (carriage up)			
SS0115-CASSRC Stainless Steel Ball Carriage	Load Rating	CB0115-CASSRC Polymer Ball Carriage	Load Rating
x1	65 lbs.	x1	40 lbs.
x2	120 lbs.	x2	70 lbs.
x3	155 lbs.	x3	90 lbs.
Flat Mount (carriage down)			
SS0115-CASSRC Stainless Steel Ball Carriage	Load Rating	CB0115-CASSRC Polymer Ball Carriage	Load Rating
x1	90 lbs.	x1	50 lbs.
x2	155 lbs.	x2	90 lbs.
x3	200 lbs.	x3	120 lbs.

Note: Weight should be evenly distributed across the carriage(s).

Preparing the Track

1. Select the appropriate length of aluminum track.
2. Calculate the length of track required, keeping in mind the following measurements: each end stop is .39" [10 mm] wide and each carriage 4.37" [111mm] long.
3. Cut track to the determined length. Multiple lengths of track may be butted together for a longer span. When joining multiple lengths of track, pinning the track ends together provides increased stability.
4. Using the centerline on the front face of the track for guidance, measure along the length of the track and drill fixing holes as required. Each hole should be .17" [4.2mm] in diameter, fully countersunk. Holes should be placed 4–8" [100–200mm] apart and between 2–3" [50–75mm] from each end of the track. (Figure 1)
5. Using the two guidelines on the back of the track, measure .20" [5mm] in from each end of the track and drill holes .17" [4.2mm] in diameter, fully countersunk. Two holes per end, four holes total. (Figure 2)
6. If the track is to be permanently joined using the drill jig, place the jig within the end(s) to be joined, clamp it to the track surface and manually drill through the jig holes, into the end of the track using a 3mm drill bit. The depth of this hole is dependent on the size of pin that will be used. Note: Pins are not supplied. (Figure 3)
7. Clean the track of any particles and proceed to the assembly stage.
8. Fix one end stop to one end of the track using two screws. Leave the other end of the track open. (Figure 4)

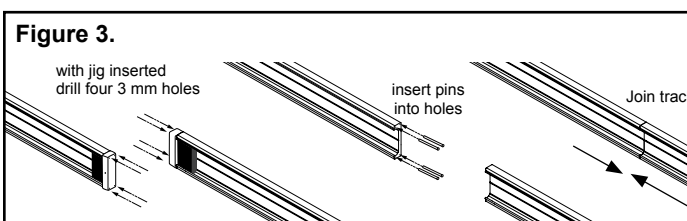
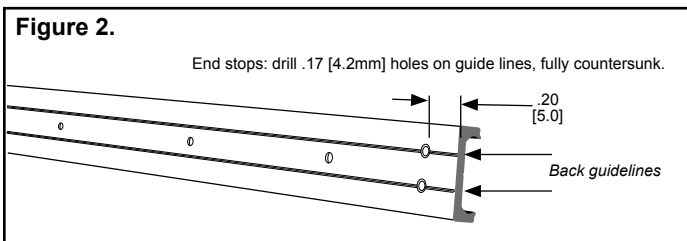
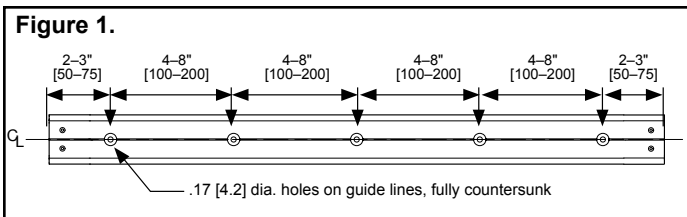

Installing the Carriage

9. Align the outer plastic sheath of the carriage to the aluminum track and butt the end of the plastic sheath against the end of track. (Figure 5)
10. Slide the carriage from the plastic sheath into the aluminum track. (Figure 6)

Important Note: Ensure the plastic sheath is fully pressed against the aluminum track before sliding the carriage through; otherwise the unit will fall out and drop ball bearings. Use a flat and even surface for this action to avoid misalignment.

11. Repeat until all carriages are installed within the confines of the track.
12. Install the other end stop using two screws. Mount slide as desired.

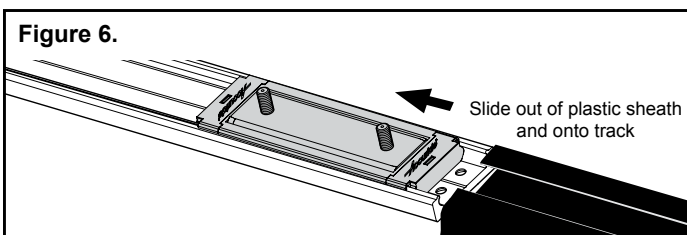
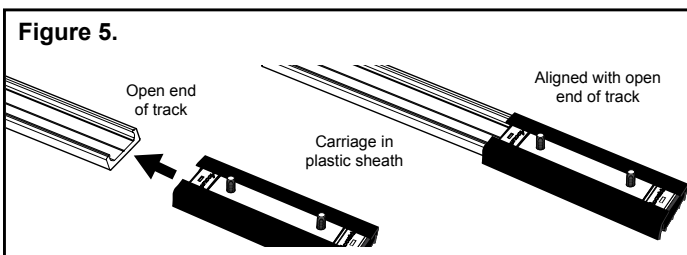

The optional Easy-Close kit (CB115-ECRC) consists of two components, the mechanism housing and the engagement pin plate. (Figure 7)

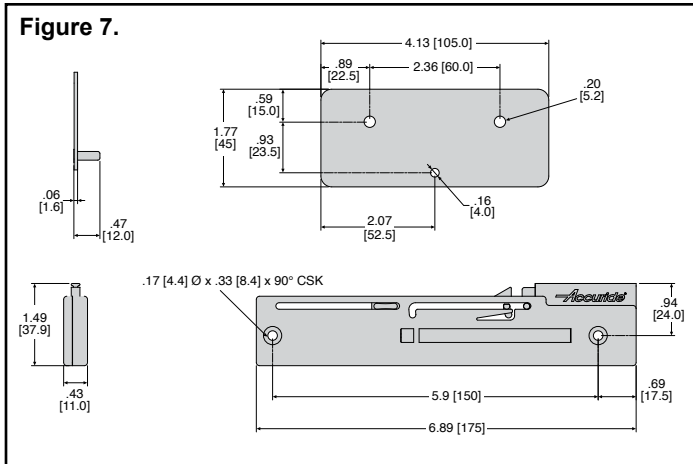

- The 115RC Easy-Close device can be installed at the beginning and end of the track to dampen motion at either end of the travel distance.
 - A 3-lb. pull force provides resistance akin to a hold-in detent, holding components in place at the end of travel.
 - Maximum load capacity is 44 lbs. [20kg]. This is based on a side-mounted track with one ball carriage suspending weight. **Applications should be tested to ensure the best performance.**
1. Using M4 [4mm] countersunk screws, mount the mechanism housing adjacent and parallel to the track. The distance from the centerline of the track to the centerline of the mechanism holes should measure 1.75" [44.5 mm]. The distance of the mechanism from the end of the track is determined by the location of the end stop. (Figure 8)

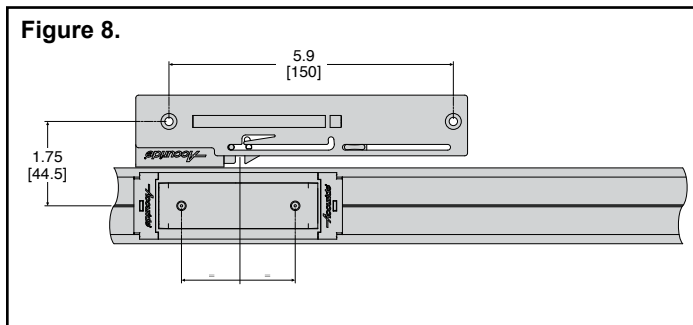

2. Install the engagement plate to the threaded studs of the ball carriage. This places the pin in the correct position to engage the Easy-Close action.

NOTE: If using multiple Easy-Close devices in multiple tracks together, be sure they are aligned to one another to ensure proper operation.

Tracks and carriages are packaged and sold singly. Fasteners are not included with track. For each complete span of track, order two End Stop Kits (AL0115-STOPRC).

Components

- AL0115-0120RCH** 47" [1.2m] Aluminum track (x1)
-with predrilled holes
- AL0115-0240RCH** 94" [2.4m] Aluminum track (x1)
- with predrilled holes
- AL0115-0120-RC** 47" [1.2m] Aluminum track (x1)
-no predrilled holes
- AL0115-0240RC** 94" [2.4m] Aluminum track (x1)
- no predrilled holes
- SS0115-CASSRC** Carriage - Stainless Steel Balls (x1)
- CB0115-CASSRC** Carriage - Polymer Balls (x1)
- AL0115-STOPRC** Aluminum End Stop
(1 stop + 2 screws)

Order example

Complete your slide order for model 115RC by specifying the following:

	Qty	P/N	Length
Total Tracks	2 ea.	AL0115	0120RC
	Qty	Carriage type	
Total Ball Carriages	2 ea.	SS0115-CASSRC	
	Qty	P/N	
End Stop Kits	2	AL0115-STOPRC	

Optional accessories

- Drilling Jig** **DZ0115-DJIGRC**
Made to order – Locates holes to pin multiple lengths of track together.
- Easy-Close Kit** **CB0115-ECRC**
Includes mechanism and engagement pin plate. Fasteners not included. Slows movement at end of travel
- 115RC Hardware Kit** **P/N 4180-0746-XE**
2ea. SS0115-CASSRC
2ea. AL0115-STOPRC
4 ea. MX 5/8" Barrel Nuts
4 ea. Star Washers

NOTE: Specifications, materials, prices, and terms and delivery are subject to change without notice.



ACCURIDE INTERNATIONAL INC.

12311 Shoemaker Avenue
Santa Fe Springs, CA 90670
TEL (562) 903-0200
FAX (562) 903-0208

www accuride.com

Manufacturing, Engineering, and Sales

United States • Germany • Japan • Mexico • United Kingdom • China

Copyright © 2014 Accuride International Inc. 3700-9545(1246)-MK973-R4-0616