

APPLICATIONS: EIA rack-mount chassis, cash drawers, industrial workstations, medical emergency carts, and vending machines.
Use Model 3306DO when a lock-in and detent-out only is required.

Medium Duty, Lever Disconnect
Over Travel, Lock-In, Detent-Out
Up to 150 lb. [68 kg.]

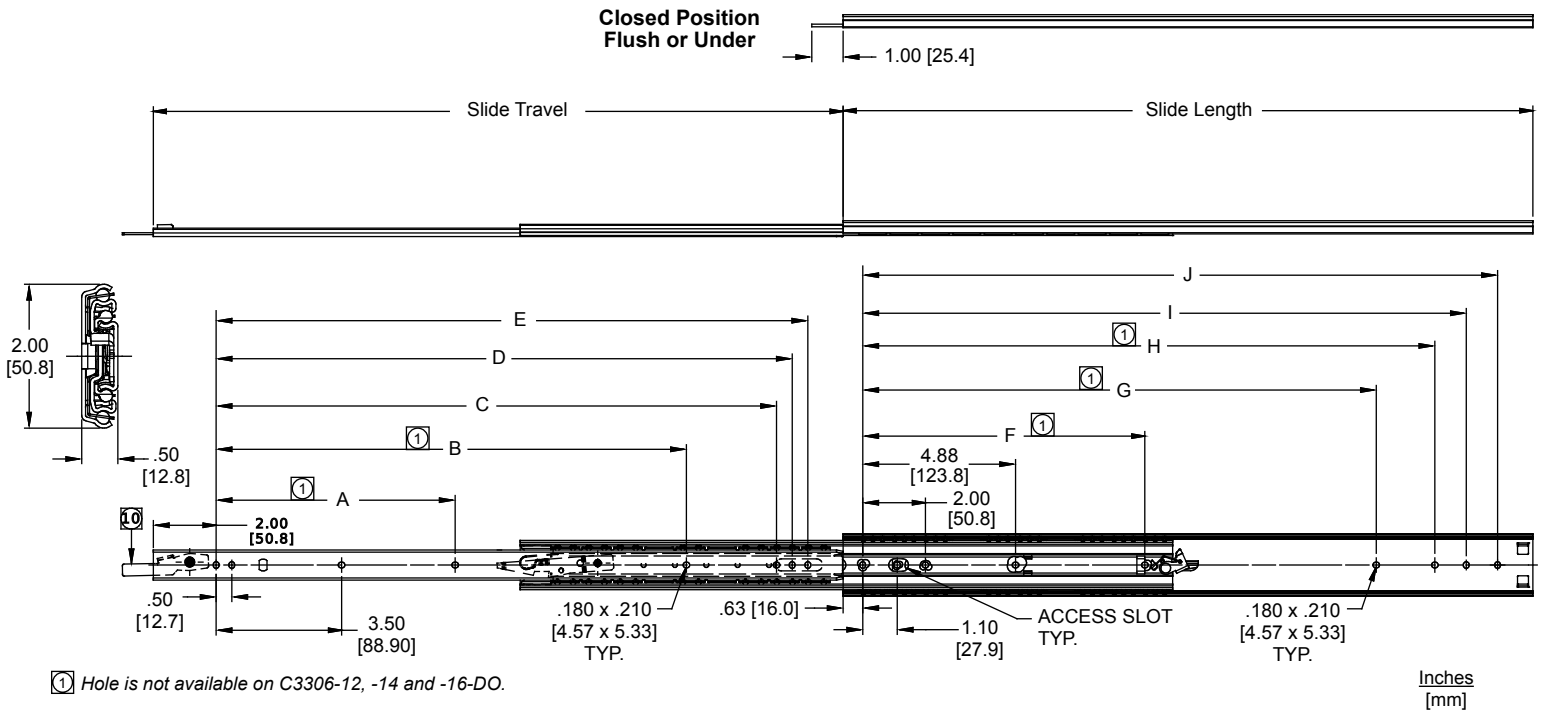

- | | |
|---|---|
| Finish: Bright electro-zinc (C) plating only | Mounting: Bracket or hard mounting |
| Lengths: 12"–28" [305 mm–711 mm] | Movement: Steel ball bearing |
| Travel: Slide length plus 1" [25.4 mm] | Hardware: #8 pan head screw |
| Height: 2.00" [50.8mm] | Disconnect: Lever disconnect |
| Load: Up to 150 lb. [68 kg.]* | Features: Lead-in pins guide chassis during reinsertion. |
| Side Space: .50" +.015 / -.000 [12.7 mm +0.4 / -0.0] | |

Part Number	Slide Length	Slide Travel	*Load Rating lb. [kg.] per pair	A	B	C	D	E	F	G	H	I	J
3306-12-DO	12.00 [305]	13.00 [330]	150 [68.2]			7.88 [200.1]	8.38 [212.8]	8.88 [225.5]			8.25 [209.5]	9.25 [234.9]	10.25 [260.3]
3306-14-DO	14.00 [356]	15.00 [381]	148 [67.3]			9.88 [250.9]	10.38 [263.6]	10.88 [276.3]			10.25 [260.3]	11.25 [285.7]	12.25 [311.1]
3306-16-DO	16.00 [406]	17.00 [432]	147 [66.8]			11.88 [301.7]	12.38 [314.4]	12.88 [327.1]			12.25 [311.1]	13.25 [336.5]	14.25 [361.9]
3306-18-DO	18.00 [457]	19.00 [483]	146 [66.4]	5.63 [143.0]	11.00 [279.4]	13.88 [352.5]	14.38 [365.2]	14.88 [377.9]	7.00 [177.8]	12.38 [314.4]	14.25 [361.9]	15.25 [387.3]	16.25 [412.7]
3306-20-DO	20.00 [508]	21.00 [533]	145 [65.9]	6.63 [168.4]	13.00 [330.2]	15.88 [403.3]	16.38 [416.0]	16.88 [428.7]	8.00 [203.2]	14.38 [365.2]	16.25 [412.7]	17.25 [438.1]	18.25 [463.5]
3306-22-DO	22.00 [559]	23.00 [584]	140 [63.6]	7.63 [193.8]	15.00 [381.0]	17.88 [454.1]	18.38 [466.8]	18.88 [479.5]	9.00 [228.6]	16.38 [416.0]	18.25 [463.5]	19.25 [488.9]	20.25 [514.3]
3306-24-DO	24.00 [610]	25.00 [635]	135 [61.4]	8.63 [219.2]	17.00 [431.8]	19.88 [504.9]	20.38 [517.6]	20.88 [530.3]	10.00 [254.0]	18.38 [466.8]	20.25 [514.3]	21.25 [539.7]	22.25 [565.1]
3306-26-DO	26.00 [660]	27.00 [686]	127 [57.7]	9.63 [244.6]	19.00 [482.6]	21.88 [555.7]	22.38 [568.4]	22.88 [581.1]	11.00 [279.4]	20.38 [517.6]	22.25 [565.1]	23.25 [590.5]	24.25 [615.9]
3306-28-DO	28.00 [711]	29.00 [737]	120 [54.5]	10.63 [270.0]	21.00 [533.4]	23.88 [606.5]	24.38 [619.2]	24.88 [631.9]	12.00 [304.8]	22.38 [568.4]	24.25 [615.9]	25.25 [641.3]	26.25 [666.7]

* Load rating based on a 16" wide drawer cycled 10,000 times.

Installation Instructions

Instructions to Bracket Mount

- To ensure proper operation of the slides, ensure that all bracket mounting screws (#8-32) are inserted so that the screw heads are inside the slides. (No washers on the inside of the slides.)
- Separate slide members by actuating the disconnect lever.
NOTE: Slides are handed.
- Using mounting kits and brackets, mount brackets to slide outer members (largest). For adjustment purposes, screw the back brackets on loosely.
- Install slides into EIA rack with #10 x 32 screws (customer supplied) and secure with bar nuts. Rear adjustment is possible by aligning the back bracket. Do not tighten screws until final adjustment is made.
- Mount slide drawer members (smallest) to the chassis. Position slides 1/8" [3.2 mm] from the front edge of the chassis making sure both slides are parallel. Lock-in latch will extend through drawer front cut-out. Ensure right hand and left hand slide members are mounted to mate with correct hand slide.
- With cabinet members in the closed position and retainers fully forward, install chassis by engaging the slide members and close completely. Check slide alignment by opening and closing the chassis. Any sign of binding indicates lateral stress or misalignment.
- Adjust slide position until movement is smooth. Tighten all screws and if necessary, use more screws to secure slides and complete installation.

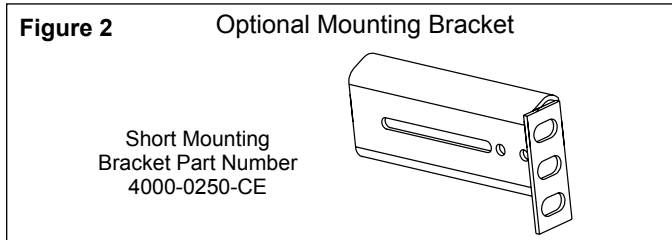
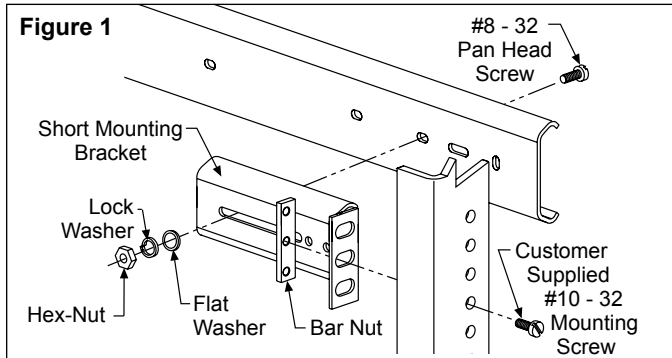

Instructions to Hard Mount

- Follow steps 1 and 2 of "Bracket Mount" instructions.
- With slides fully extended, install slide cabinet members (largest) into cabinet using #8 pan head screws. Ensure slides are parallel.
- Mount slide drawer members (smallest) to the chassis. Leave all screws loose for future adjustment. Ensure slides are parallel and handed members mated properly.
- Follow steps 6 and 7 of "Bracket Mount" instructions.

Ordering Procedure

Complete your slide order for model 3306DO by specifying the following:

	10 pair	C	3306	-18	-DO	D
Total Slides Required _____						
Slide Finish _____						
Slide Model _____						
Slide Length _____						
Detent Out _____						
Optional Polybag Packing _____						

Optional Mounting Brackets

Optional mounting brackets are ordered as **kits** or **bulk**.

Each **kit** contains enough brackets and hardware to mount one pair of slides. Order kit part number 4180-0219-XE.

	10 each	4180-0219-XE
Total Kits Required _____		
Kit Part Number _____		

Bracket kit includes the following. See Figure 1.

- 4 short brackets (part number 4000-0250-CE)
- 1 bracket hardware kit* (part number 4180-0230-XE)

(*Kit contains screws, hex-nuts, washers, bar nuts.)

For **bulk**, order 4 each short brackets and 1 hardware kit per pair of slides required. See Figure 2.

	20 each	4000-0250-CE
Total Brackets Required _____		
Bracket Part Number _____		

	20 each	4180-0230-XE
Total Hardware Kits Required _____		
Hardware Kit* Part Number _____		

(*Kit contains screws, hex-nuts, washers, bar nuts.)

Packaging

Distributor (D) Pack: Polybag contains one pair of slides and one slide mounting hardware kit. Brackets ordered separately.

- Lengths 12"–20" 10 pair per box
- Lengths 22"–28" 5 pair per box

Bulk (P) Pack: Slides and optional mounting bracket kit are ordered and packaged separately.

- Lengths 12"–22" 10 pair per box
- Lengths 24"–28" 7 pair per box

Specifications

Slide members and ball retainers: Cold rolled steel
 Ball bearings: Carburized steel
 RoHs compliant

NOTE: Specifications, materials, prices, terms, and delivery are subject to change without notice.



Accuride International Inc.

12311 Shoemaker Avenue
 Santa Fe Springs, CA 90670
 TEL (562) 903-0200
 FAX (562) 903-0208

Manufacturing, Engineering, and Sales
 United States • Germany • Japan •
 Mexico • United Kingdom • China

For the most current technical information visit www.accuride.com

⚠ WARNING: This product can expose you to chemicals including nickel, which is known to the State of California to cause cancer and birth defects or other reproductive harm. For more information go to www.P65Warnings.ca.gov.